

Protection System for Power Amplifiers

An indispensable companion for the paX amplifier

Jan Didden

In Part I and part 2 about the paX amplifier we developed a complete error-correction power amplifier. In this accompanying article a protection system is described that's constructed on a separate small circuit board for mounting directly on the speaker binding posts. We will also discuss the Safe Operation Area for the output devices and how it is modelled in the protection system.

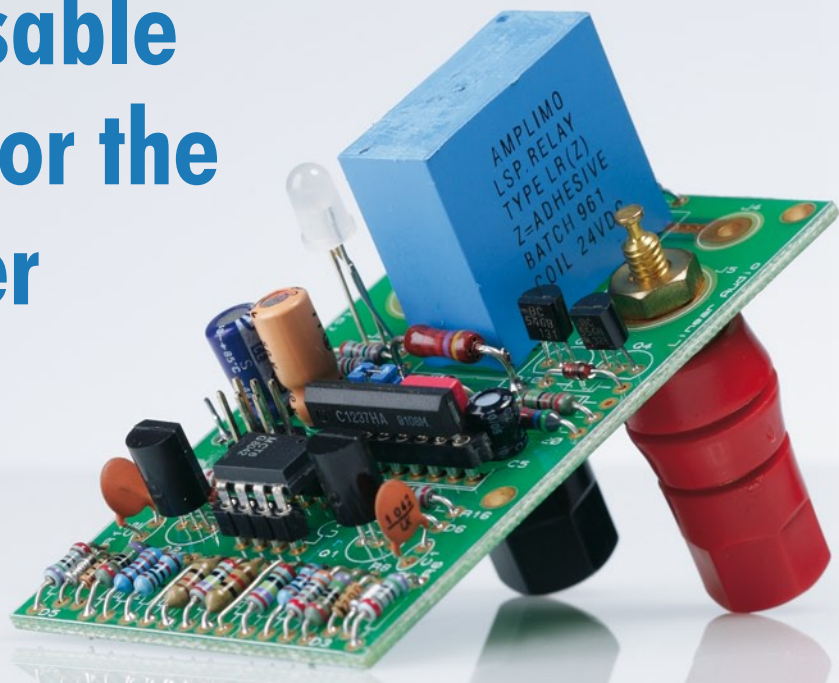

A good protection system for an audio amplifier has two important tasks: speaker protection and amplifier overload protection. Speaker protection concerns a possible excessive DC voltage at the amp output due to either excessive ultra-low frequency signals, or from a circuit failure inside the amp. By the way, you can also get excessive DC output if you have a DC coupled power amp and your preamp gives out DC. If you go on tour with your amp, it would be wise to insert

– even temporarily – some input coupling caps.

There are many convoluted circuits to disconnect the speaker from the amp through a high-power relay in case of significant DC offset at the output. These circuits often do double duty in delaying the closing of the relay until after the turn-on transient, as well as immediately opening the relay when power is switched off – again to avoid transient thumps in the loudspeaker.

I used a low-cost, purpose-designed, but not too well known IC: the uPC1237 from, among others, NEC. The NTE7100 from NTE Electronics, is pin- and functionally compatible. It's an 8-pin single-in-line (SIL) chip with all the functions mentioned above. The datasheet gives the formulas for calculating the component values. It can handle two channels for a stereo amp, but I used one chip per channel to make it easier to construct the amp as dual mono.

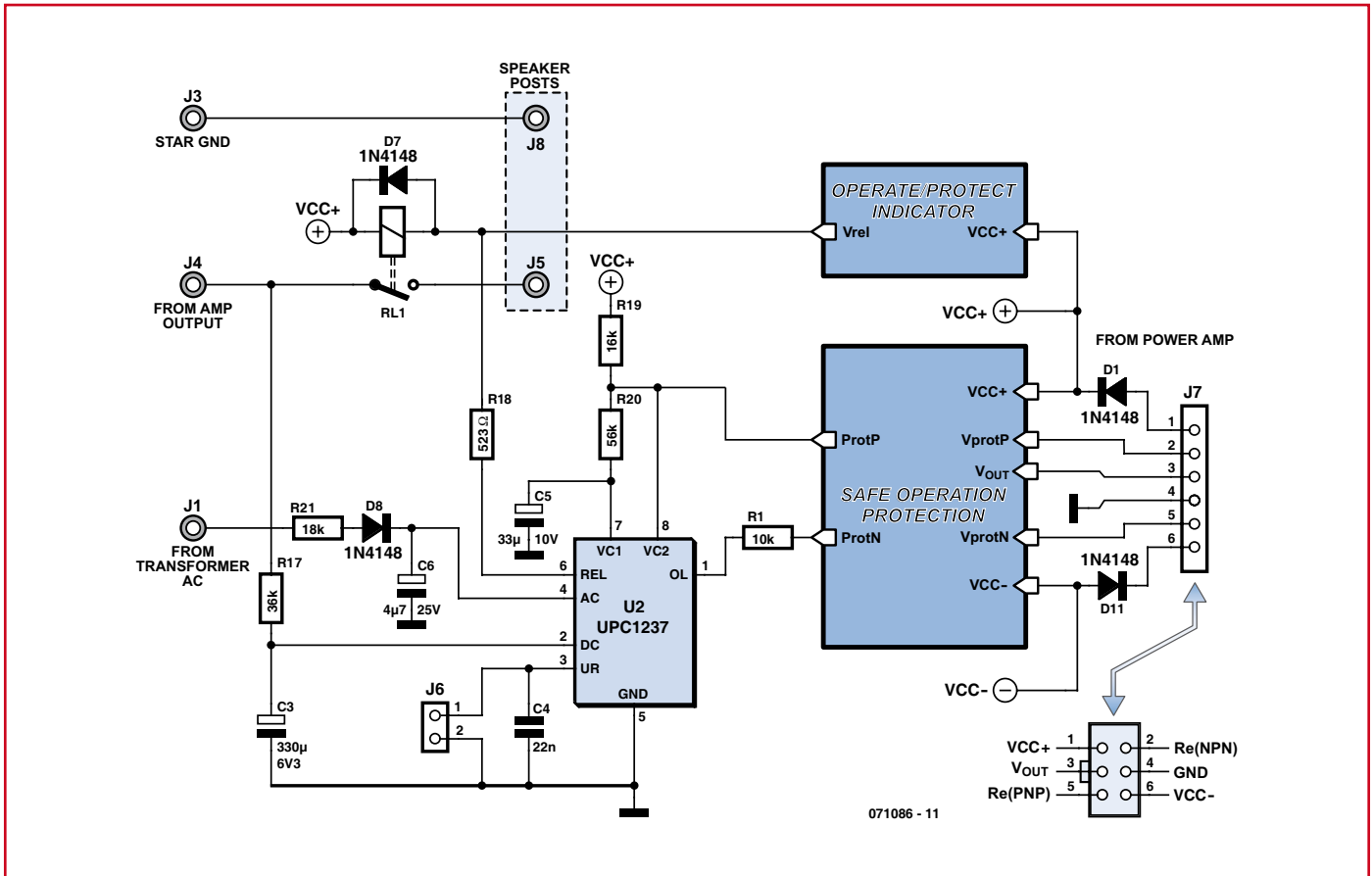

Figure 1. Overall protection system.

For the speaker relay I used a little-known device specially designed for this function and sold by the Dutch company Amplimo. The relay has two parallel internal contacts, one heavy-duty tungsten 100 A contact and a smaller gold contact pair. When the relay closes, the tungsten contact closes first, and is then bridged by the gold contact. The reverse takes place when opening the relay.

Circuit diagrams

The overall protection system is shown in **Figure 1**. The blocks for the Indicator and the Safe Operation Area protection will be described later. The uPC1237 has an internal 3.4 V shunt regulator at pin 8, and the supply current is provided by R19 and R20. The relay switching output (pin 6) drives the relay through R18. Jumper J6 sets the circuit operation. If J6 is closed, the circuit becomes 're-entrant': if there is an error input, the relay falls off, and after a short delay is activated again. If, at that point, the error has disappeared, the relay stays activated, if not, it falls off again and the cycle re-

peats. If J6 is not closed, the relay is deactivated when an error is present and you have to switch the power off and on again to reset the circuit.

DC offset shut-off

Pin 2 of U2 is the DC offset input. AC on the amplifier output signal is removed by R17-C3 and the DC offset is sensed. Although the uPC1237 only has a unipolar supply (the amplifier's VCC+), pin 2 does accept bipolar signals. The calculations are a bit complex because the internal positive and negative thresholds are not equal. It is all explained in the datasheet. With some care you can set the threshold for positive and negative offset to the same value at $0.6 V_{DC}$. These values are set by R17 and C3 as shown in **Figure 1**.

Switch-on delay

You will also see that a sample of the AC from the supply transformer is connected to the uPC via R21 and D8 to C6. This part of the circuit will delay the loudspeaker switch-on after a power up to make sure the amp has stabilized and there are no switch-on

thumps. When the power is turned off, this signal will disappear immediately, before the supply capacitors have a chance to discharge. This way the speaker relay will be opened before the turn-off thumps occur.

Safe Operation Area

The second main part of the protection system is to guard the output devices against excessive low impedance loads and short-circuits. Michael Kiwanuka has written a very informative article on Safe Operation Protection in audio power amplifiers [1]. My own protection circuit is different, but was inspired by Mike's design and has many things in common with it. **Figure 2** shows the circuit. The circuit receives two types of information from the power amp: the I_c in the output devices through V_{protP} and V_{protN} (via connector J7 in **Figure 1**): this actually is the voltage across the emitter resistors. Secondly, through the components connected to the supply and V_{out} a voltage is developed that represents V_{ce} of the output devices. (There is a separate part to this article that explains the circuit in detail and how

Calculating and setting up the protection system

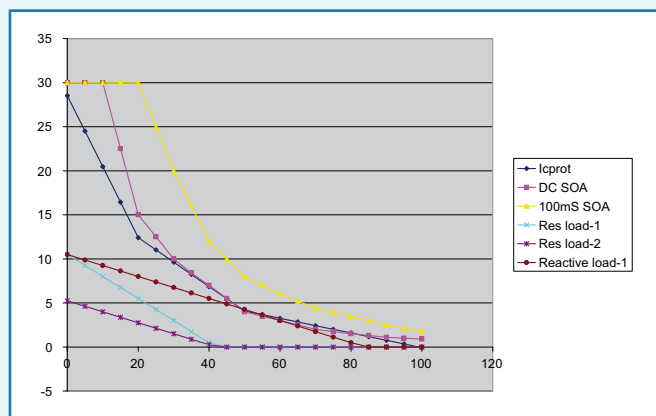

Figure 1. SOA, load lines and protection locus. See text for explanations.

The paX amplifier uses Safe Area Operation (SOA) protection. In this section we will address the specific design equations and how to develop the circuit values for the SOA part.

Figure 1 shows the various curves that we need to develop the SOA protection for two pairs of output devices. I_c (A) is on the vertical scale, V_{ce} (V) is on the horizontal scale. When V_{ce} is zero, it means that V_{out} is equal to V_{supply} . In practice, there will always be a few volts V_{ce} remaining at maximum output, but we will disregard that for the moment. The cyan curve shows the safe combinations of DC I_c and V_{ce} for two parallel STD03 Sanken Darlington devices used in this amplifier. The yellow curve shows this for loads lasting no longer than 100 ms. That means that combinations of I_c and V_{ce} that fall below and to the left of the curve, are safe, but as soon as the curve is crossed, the protection system should activate. Since music is impulsive and not DC, one could argue that protection for the yellow curve would be sufficient, but if we use the cyan curve we have an additional safety factor and we also are protected against DC shorts.

Figure 1 also shows some load lines, which are combinations of I_c and V_{ce} required to drive a (resistive) load, assuming ± 40 V supplies. The lower one, in pink, is an 8 Ω load, the light blue one is 4 Ω . For example, in the 4 Ω case, we see that when $V_{ce} = 0$, the output voltage is the supply voltage (40 V in this case) and thus I_{out} in 4 Ω is 10 A. The brown curve is also for 4 Ω load, but now with a maximum reactive component of 90° phase shift. This is a particularly mean load. At $V_{ce} = 40$ V we are exactly between the supplies (assuming a ± 40 V supply) with $V_{out} = 0$. With $V_{ce} = 60$ V, V_{out} is actually -20 V negative but I_c is still positive (about 3 A). That means that the upper

transistor (N device) sources current even with a negative V_{out} ! Under these circumstances (which can happen easily with real speaker/crossover loads) quite high V_{ce} to I_c combinations can occur although the device dissipation is very much limited as shown in the SOA curve. For instance, in this example, at $V_{ce} = 60$ V and $I_c = 3$ A, allowed dissipation (per device!) is 90 W, although the data sheet calls this a 160 W device.

So, we can put in a simple current limiter that follows, say, the 4 Ω complex load line. But then we cannot use the large safe area, especially at low V_{ce} and I_c between 10 A and 30 A, which may come handy with speaker loads that have low impedance dips. It is clear from Figure 1 that a simple current limiter is not enough. What we want is to 'model' the cyan DC curve in our circuit. This can be done with some non-linear circuit elements, and my target SOA protection curve is shown in dark blue. It has three inflexion points at $V_{ce} = 20$ V and $V_{ce} = 50$ V.

The way I implemented this is shown in Figure 2, which is the positive half of the full circuit given in Figure 2 of the article about the protection circuit. (The negative part works similarly and will not be discussed). There are 4 distinct points on the blue target curve. The first and last points are defined by $V_{ce} = 0$ and $I_c = 0$ respectively. The other breakpoints are at $V_{ce} = 20$ V and $V_{ce} = 50$ V. These two breakpoints are caused by diodes D3 (for 20 V/13 A) and D2 (for 50 V/5 A). Remember, all currents are for two parallel devices! At each breakpoint, the diode(s) start to conduct and shunt current away from R14 and R4, so that Q1 conducts later.

To calculate the component values for this rather involved circuit, we start with the simple part: if $V_{ce} = 0$, the maximum allowed I_c is 30 A for two output pairs. Also at this point, $V_{out} = V_{CC+}$ so there is no current coming from R6/R5. The voltage to turn on Q1 comes exclusively from the voltage drop across the output devices' emitter resistors, through Rs. We need to ensure that at 30 A, the voltage at Q1 (base) is approximately 0.65 V. Although there are two emitter resistors and two Rs resistors in the circuit, they are in effect parallel, so we will use from now on $R_e = 0.11 \Omega$ and $R_s = 50 \Omega$. With 30 A through the parallel value of R_e , $V_{Re} = 3.3$ V, which is attenuated through Rs and R4: $12/(50+12) \cdot 3.3 = 0.64$ V — close enough.

Now it gets interesting. Lets move to the breakpoint where $V_{ce} = 20$ V. The allowed I_c is (cyan curve) about 13 A. We assume some values and then calculate the rest: $R_s = 100 \Omega$, $R_4 = 12 \Omega$; we set R14 to 270 Ω . Let's disregard D2/R8 and D3/R7 for the moment; we just need to be sure later that that was justified (that the diodes don't conduct at up to $V_{ce} = 20$ V). $V_{ce} = 20$ V and $I_{cmax} = 13$ A gives an effective V_s of $V_s = R_4/(R_s+R_4) \cdot (R_e \cdot I_c)$, which, with the given values, is 0.28 V. We need $V_b = 0.65$ V, so the current from R5 should gener-

I calculated the various component values).

The purpose of the SOA protection is to limit the combinations of V_{ce} and I_c for the power devices to a safe value. Normally, such a protection circuit would be arranged to take away the drive from the output driver transistors to limit the available output current. The protection transistor (Q1 or

Q2, Figure 2) collector would normally be connected to the base of the (pre) driver transistor in the output stage. Q1/Q2 turns on when its V_{be} exceeds about 0.65 V, shunting driver base signal away. But in my experience, even with a V_{be} of only a few 100 mV, the protection transistor starts to influence the driver base signal, resulting in increased error correction and increased distortion.

For this reason I decided to make this an on/off protection circuit: the protection transistors drive the 'overload' pin (1) of the uPC1237 through the dual optocoupler U1, an MCT6. If overload occurs, pin 1 of the uPC is set high via R1 (Figure 1) and the uPC opens the speaker relay. I have the uPC set for auto re-entry by jumpering J6: in this mode, the speaker relay will be periodically closed

ate the remaining 0.37 V across R14. So this current needs to be $I_{R5} = 0.37/270$ or 1.37 mA, which also flows through R6 of course. With a V_{ce} of 20 V (we disregard the small V_{ce} loss across R_e), that would make $R5+R6 = (20-0.65)/1.37 = 14.1$ k Ω . It doesn't really matter how we split up the total value (it does matter for the other values of course, but not for the functioning), so let's make them equal: $R5 = 7$ k Ω and $R6 = 7$ k Ω .

At this breakpoint, $V_{ce}=20$ V, diode D3 should be on the verge of conducting, so D3 should be a zener equal to the value of V_m . Since we have 1.37 mA through R6, $V_m = 20 - (1.37 \cdot 7) = 10.4$ V, making D3 a 10 V zener.

Now let's move to the next point, 50 V/4 A. Analogous to the 20 V/13 A point, D2 should be on the verge of conducting so we can disregard it, and R8, for now.

As before we calculate the contribution of I_c at V_s : $V_s = 12/(12+50) \cdot (0.11 \cdot 4)$ which is 85 mV, so the V_{ce} -derived current from R5 and R6 should add $0.65-0.085 = 0.565$ V at V_b , therefore

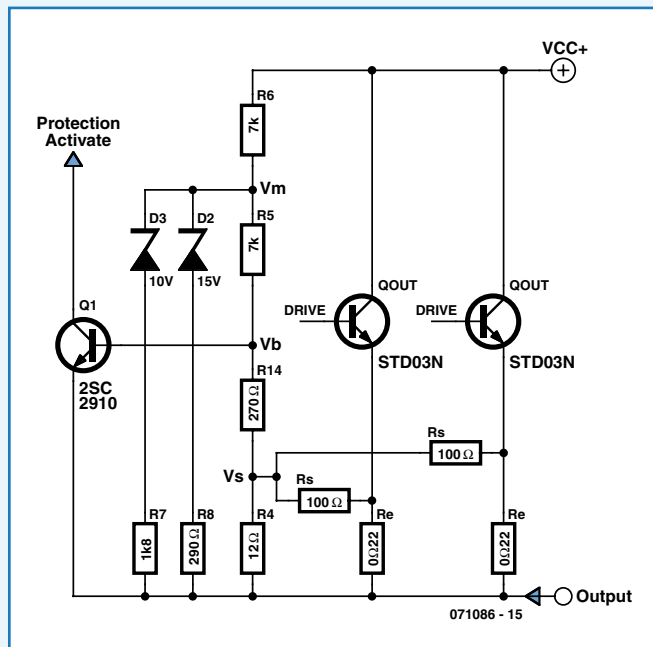

Figure 2. SOA protection circuit.

$I_{R14} = 0.565/270 = 2.1$ mA. This 2.1 mA also flows through R5 and R6, so $V_m = 0.65 + (2.1 \times 7) = 15.35$ V. (This of course means that D2 should be a 15 V zener, and we will use that later).

With $V_m = 15.35$ V and D3 a 10 V zener as calculated above, we

have 5.35 V across R7. The voltage across R6 now is $V_{R6} = 50-15.35 = 34.65$ V, so $I_{R6} = 34.6/7k = 5$ mA. Since 2.1 mA flows through R5, 2.9 mA must flow through R7 with 5.35 V (V_m-10 V from D3) across R7, so $R7 = 1.8k\Omega$.

Moving on now to 100 V/0 A, it gets pretty boring:

$I_c=0$ so there is no contribution from R_e to V_s , and the $V_{be} = 0.65$ has to be generated by the current through R5 and $R14+R4$, so $I_{R14+R4} = 0.65/282 = 2.3$ mA. This current also flows through R5 so $V_m = 2.3 \cdot 7 + 0.65 = 16.75$ V.

The current through R6 is: $I_{R6} = (100-16.75)/7 = 12$ mA, so the excess of 12 mA-2.3 mA = 9.7 mA needs to be shunted away through D2/R8 and D3/R7.

$V_{R7} = (16.75-10) = 6.75$ V with R7 at 1.8 k Ω so $I_{R7} = 3.75$ mA, which sets I_{R8} to $9.7-3.75 = 6$ mA.

$V_{R8} = 16.75-15 = 1.75$ V so $R8 = 290 \Omega$.

So, there you have it, but it would be nice if there was some way to verify this before committing solder (and parts). We have disregarded several things, for instance the loss of V_{re} for V_{ce} and several roundings in the calculations. I have developed a spreadsheet to try to double check all this (available on www.linearaudio.nl and www.elektor.com). It works backwards from what we just did: using the component values in the circuit, it calculates at each V_{ce} the V_b contribution from the current through R5, and then finds the I_c that would add just enough voltage across R_e to make $V_{be} = 0.65$ V. Plotting those pairs of V_{ce} and I_c then should give us the actual (blue) SOA curve we wanted in the first place. What we see is that the spreadsheet shows reasonable correspondence to our values, but there are some deviations. The reason is that once I had the spreadsheet, I 'played' with the component values to get the best fit to the SOA curve, or to get 'nice' values for parts. I used a V_{CC} of 44 V and a $V_{ce(min)}$ of 2 V in the spreadsheet. Also, manipulating the R5 and R6 ratio lets you home in on standard zener values. The way to do that is to use Excel's solver to find the ratio of R5 to R6 that results in say $D3 = 12$ V. Some more playing then gets you to $D2 = 18$ V. In the end, I used the values from the spreadsheet in the actual circuit as given in the main article. Since we stayed on the safe side with the blue protection curve, small deviations won't cause disaster. Just try it, you can't break anything, but don't mess with the formulas unless you know exactly what you're doing!

I developed this spreadsheet for this particular application and did a fair amount of checking, but I cannot guarantee that it is without errors. If you find any, please let me know and I will update it, giving credit where it is due, of course.

It is not so easy to test the accuracy of such a protection system in real world, and mistakes could be expensive. So this double check of calculating the values and then working backwards to verify them is important to gain confidence in the circuit.

to see if the overload still exists, and if so, it is opened again immediately.

It can be argued that the protection system should work by limiting the output in case of overload and not by disconnecting the speakers. I would agree that for PA duty this would be preferred, but for home use it is a very minor nuisance, if at all. But doing it this way prevents influencing of the music signal by the circuit

when there is no need for protection activation. Having used this amp for about a year now, I have never seen the protection system disconnect the speakers, except in one case where I had a problem with a balanced cable which put a signal with 2.5 V_{DC} on the amplifier input. I immediately heard the on-off cycling of the amplifier, so I switched it off and managed to find the problem. After solving the

problem all was as it should be. So, for me, this works quite well.

Status indicator

Then, lastly, there is a small bi-stable circuit that takes the relay drive voltage to drive a bi-colour LED which you can place on the front panel. The LED will be one colour when the amplifier is in turn-on delay or in protection and another colour if the amplifier is oper-

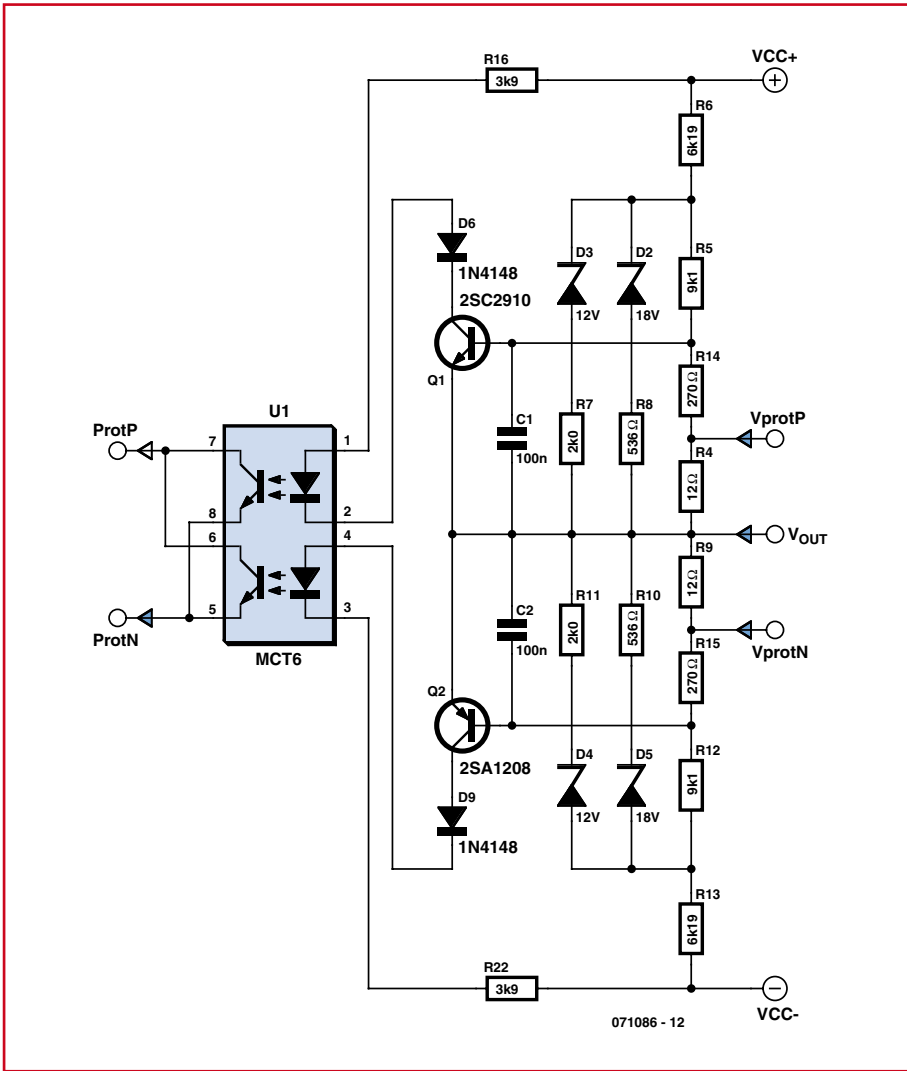

Figure 2. Safe Area Protection system.

point) to the protection board at J1 as shown. Don't connect a speaker yet, and don't yet connect the speaker wire from the amp to the protection circuit. Now, when you switch on the amplifier, you should hear the relay pull in after a few seconds. If you find it too fast, you can increase C6 for a longer delay. If you switch off the amp, the relay should immediately open again.

Next we will check the DC offset protection. Temporarily connect a resistor of 100 kΩ from the positive or the negative supply to the speaker input point on the protection board (J4). The relay should deactivate. Check this with both J6 set and removed to verify correct operation.

Then, install all components for the status indicator in Figure 3.

The PCB has labels 'ON' and 'OFF' at J2. That indicates which pin will be active at which status. If you use a red/green LED you would connect the RED pin to J2/OFF and the GREEN pin to J2/ON. You may want to repeat one of the tests described above to verify the correct operation of the status indicator.

The last part will be to complete the Safe Operation Area (SOA) protection components. Put all remaining parts on the protection board. Connect the flat cable, and connect the speaker output from the amplifier (Amplifier J3 to o/p board J4), as well as the star ground wire (o/p J3 to supply star ground).

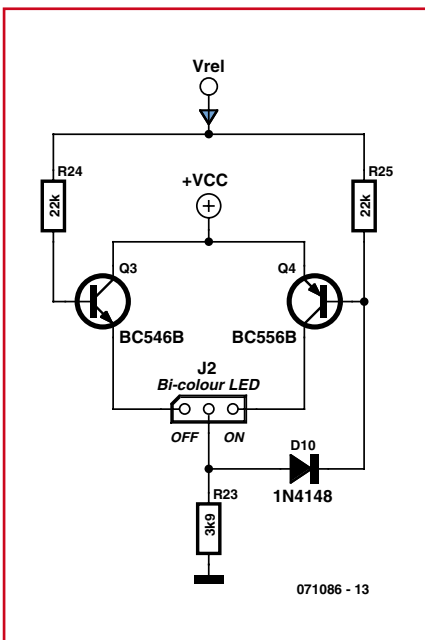

Figure 3. Status indicator.

ating normally. This circuit is shown in **Figure 3**. All components shown in figures 1, 2 and 3 are on the output/protection (o/p) board shown in **Figure 4**.

Construction

Before building the o/p board, first complete the amplifier. We need the amplifier to test the o/p board. The o/p board can be populated first with the DC and delay circuitry around U2. Start with the components shown in Figure 1.

Next, construct the 6-wire flatcable as shown in Figure 1 in the Construction Guide. Be sure to orient the notches in the 6-pin headers exactly as shown! Connect the two boards with the flatcable, again noting the header notch position as indicated on the PCB silk screen. Also connect one side of the power transformer secondary (the AC

Switch on the amplifier and verify that it works normally. Then, to simulate an overload situation, connect a resistor of 10 kΩ between the positive supply and the node Q1(base)/R14/R5/ C1 and verify that the relay falls off. Do the same with the negative supply and the node Q2(base)/R12/R15/C2.

Note: If you do not mount the o/p board directly on the speaker output posts, you can connect the speaker return wire directly from the output post to the supply star ground without going through the o/p board. The loudspeaker's 'hot' connection then goes from the o/p board J8 to the output post.

Stand-alone!

This article focused on using this o/p board with my 'paX' amplifier. But you can use it with any amplifier, provided you adjust the SOA circuit values as re-

COMPONENTS LIST

Resistors

(0.25W metal film)

R1 = 10k Ω
 R4,R9 = 12 Ω
 R5,R12 = 8k Ω
 R6,R13 = 6k Ω
 R7,R11 = 2k Ω
 R8,R10 = 560 Ω
 R14,R15 = 270 Ω
 R16,R22 = 3k Ω
 R17 = 36k Ω
 R18 = 510 Ω
 R19 = 16k Ω
 R20 = 56k Ω
 R21 = 18k Ω
 R24,R25 = 22k Ω
 R23 = 3.9k Ω 1W

Capacitors

C1,C2 = 100nF ceramic
 C3 = 330 μ F 6.3V
 C4 = 22nF ceramic
 C5 = 33 μ F 10V

C6 = 4 μ F 25V

Semiconductors

D1,D6-D11 = 1N4148
 D2,D5 = zener diode 18V 0.5W
 D3,D4 = zener diode 12V 0.5W
 J2 = dual colour LED
 Q1 = 2SC2910
 Q2 = 2SA1208
 Q3 = BC546B
 Q4 = BC556B
 U1 = MCT6 (Fairchild)
 U2 = UPC1237 (NEC) or NTE7100 (NTE Electronics)

Miscellaneous

J6 = header 2 x 1 pin
 J7 = 2 x 3 pin DIL flatcable header
 RL1 = Amplimo LS relay
 DIL socket 2 x 4
 SIL socket 1 x 8 pin
 PCB, # 071086-1 from the author or www.thepcbshop.com

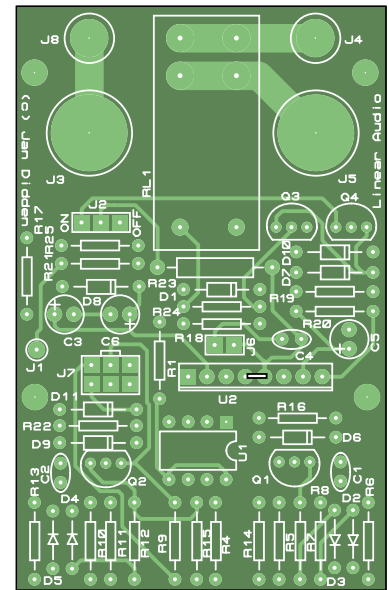

Figure 4. Component placement of the double-sided PCB for the o/p board.

quired, as described separately. The inset in Figure 1 shows the connections you need to make from your amplifier to the o/p board through J7.

(071086-1)

Literature

[1] Transparent V-I Protection in Audio Power Amplifiers, Michael Kiwanuka. Electronics World, October 2002.

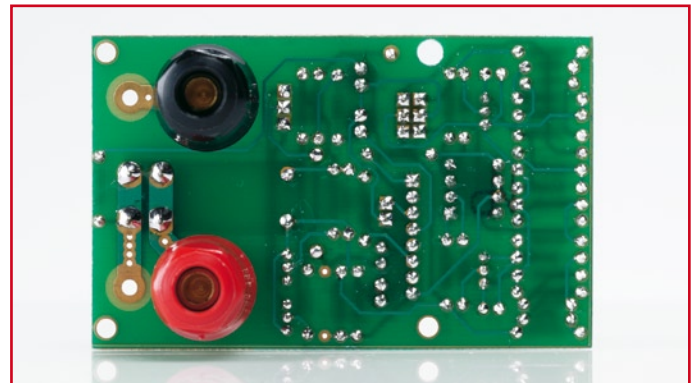
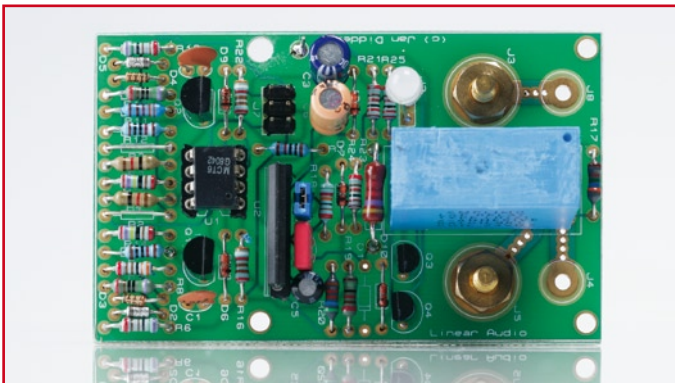

Advertisement