

FEEDBACK PLOTS DEFINE OP AMP AC PERFORMANCE

By Jerald G. Graeme (602) 746-7412

(Originally published in EDN magazine as "Feedback Plots Offer Insight into Operational Amplifiers" and "Bode Plots Enhance Feedback Analysis of Operational Amplifiers" on 1/19/89 and 2/2/89, respectively.)

Feedback plots simplify the analysis of an op amp's closed-loop AC performance by showing bandwidth and stability conditions as a function of the op amp's gain and phase response. These plots also provide insight into noise performance and the special feedback requirements of circuits such as integrating converters, photodiode amplifiers, composite amplifiers and active feedback circuits.

Engineers routinely use Bode plots⁽¹⁾ to determine the bandwidth and frequency stability of voltage-gain op amp circuits. A Bode plot provides a visual representation of an op amp's transfer response and its potential stability. Moreover, such plots define the circuit's pole and zero locations at the intercepts of the response-curve extensions.

The Bode plot of Figure 1, for example, shows the interaction of the magnitude response of the open-loop gain ($|A|$) and the reciprocal of the feedback factor ($1/\beta$). The fraction of the output that feeds back to the input is β . The voltage-divider action of Figure 1's feedback network determines the value of β ; for moderate resistance values, $\beta = R_1/(R_1 + R_2)$. For this noninverting example, the feedback equation, $A_{CL} = A/(1 + A\beta)$, defines the closed-loop voltage gain. $A\beta$ is the loop gain, and where it is high:

$$A_{CL} \approx 1/\beta = (R_1 + R_2)/R_1$$

$A\beta$ represents the amplifier gain available to maintain the ideal closed-loop response. At the point where the loop gain no longer matches the feedback demand, the closed-loop curve deviates from the ideal. The Bode plot graphically defines this limit by plotting the $1/\beta$ curve with the gain-magnitude response curve of the op amp. Because the $1/\beta$ line represents the feedback demand, closed-loop requirements will be satisfied as long as this line is below the amplifier-gain curve. Where this condition is no longer true, the actual response drops, following the amplifier's open-loop response downward. The rate of descent for the roll-off is -20dB/decade (for most op amps) and is characteristic of a single-pole response. In Figure 1, the heavier line on the gain-magnitude plot depicts the resulting closed-loop curve.

INTERCEPT DEFINES BANDWIDTH

For a basic voltage-gain amplifier, the location of the f_p pole determines the closed-loop bandwidth. In this case, a single-pole roll-off determines the point at which the gain magnitude goes below 3dB (equivalent to 0.707 of its low-fre-

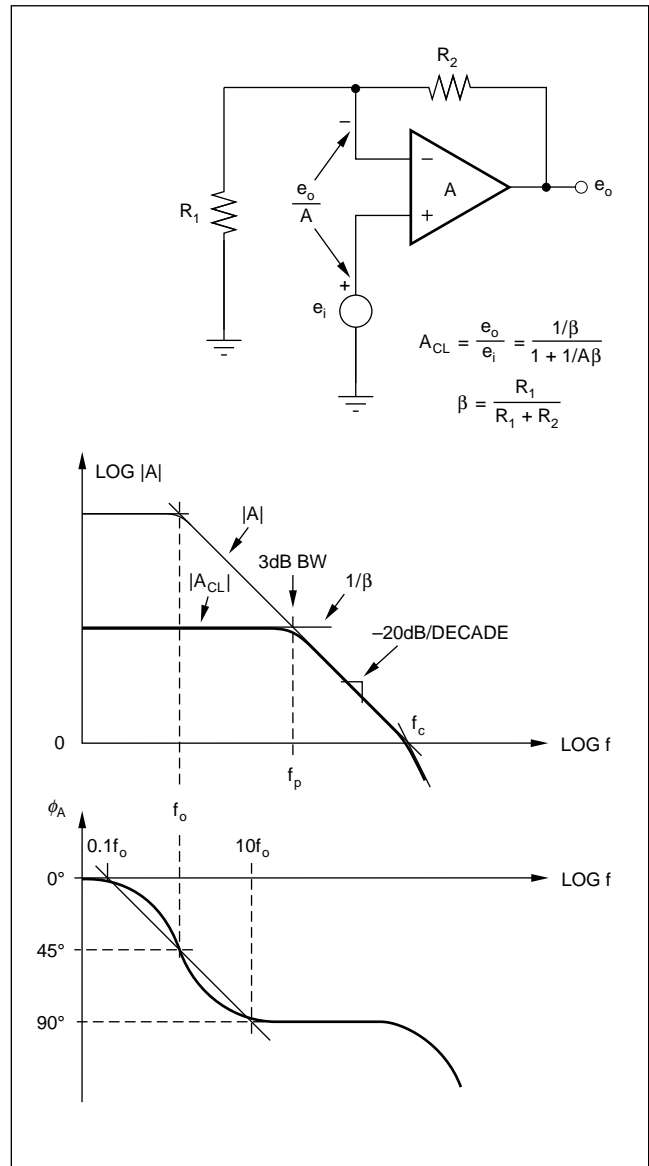

FIGURE 1. This feedback analysis provides a summary of loop conditions in the $1/\beta$ curve and defines the underlying poles, zeros, and phase shift.

quency level). To find this point relative to the Bode plots, rewrite the closed-loop gain as

$$A_{CL} = (1/\beta)/(1/A\beta + 1)$$

The bandwidth-defining gain error is a result of the $1/A\beta$ term in the denominator. Because β is constant for the circuit in Figure 1, the amplifier gain (A) determines the frequency dependence of the loop gain. For a typical op amp, the gain-

bandwidth product is constant after the first break frequency occurs and $A = jf_c/f = j|A|$ where f_c is the amplifier's unity-gain crossover frequency. For this common condition,

$$A_{CL} = (1/\beta)/(1 + 1/(j|A|\beta))$$

The bandwidth is defined in terms of the absolute value (magnitude) of A_{CL} :

$$|A_{CL}| = (1/\beta)/\sqrt{(1 + 1/(|A|^2 \beta^2))}$$

which, at the -3dB point, becomes

$$|A_{CL}| = 0.707(1/\beta) = (1/\beta)/\sqrt{2}$$

Comparing the last two expressions, you can see that the -3dB bandwidth occurs when $|A| = 1/\beta$. This equality is true when the gain supply drops to the exact level of the feedback demand. When you plot these two functions on the same graph, they reach equality at the intersection of the two curves. This intercept pinpoints the closed-loop pole location and defines the circuit bandwidth for the voltage-gain amplifier.

STABILITY PREDICTED FROM THE INTERCEPT

This critical intercept point also exhibits other characteristics that can help you define conditions for frequency stability. By relating the phase shift to the slopes of the gain-magnitude and $1/\beta$ curves, you can determine the loop phase shift at this intercept. Again, the importance of the intercept is apparent from the closed-loop-gain expression, $A_{CL} = A/(1 + A\beta)$. If $A\beta$ becomes -1 , the closed-loop gain will be infinite and will support an output signal even in the absence of an input signal, which is a condition for oscillation. The magnitude of $A\beta$ is unity only at the intercept point because it is at this point that $A = 1/\beta$; a negative polarity for $A\beta$ only requires 180° phase shift.

Virtually every practical analog circuit is a minimum-phase system. For such systems, which have only left-half-plane poles and zeros, you can directly read the phase shift from the gain-magnitude response⁽²⁾. Although many op amps do have a right-plane zero caused by Miller phase compensation, the effects of this zero are suppressed below the unity-gain crossover. For the case of a minimum-phase system, a pole creates a -20dB/decade response roll-off and a -90° phase shift; a zero produces the same effects but with opposite polarities. Additional poles and zeros simply add to the response slope and phase shift in increments of the same magnitude.

Relying on the feedback phase shift's correlation with the response slope, you can determine its value at the critical intercept from the gain-magnitude and $1/\beta$ curves. For the example of Figure 1, the gain-magnitude curve has a slope of -20dB/decade and the $1/\beta$ curve has a zero slope for a net 90° feedback phase shift at the intercept. This situation leaves a phase margin of 90° out of the 180° that would cause oscillation. Because the intercept is well removed from the open-loop-response break frequencies, the analysis of this example is easier to understand. The intercept occurs after the amplifier's first pole develops the full 90° phase shift, but well before the second pole has any effect.

APPROXIMATING PHASE MARGIN

In cases where the intercept is less than one decade from a response break, the Bode approximation of the phase shift shows a linear slope that has a maximum error of 5.7° ⁽¹⁾. For Figure 1, the phase-shift approximation starts at 0° one decade before the break frequency f_0 . From there, it increases linearly on the log scale to 45° at the break frequency and then to 90° one decade above it.

Using this approximation, you can combine the stability criteria for loop-gain magnitude and feedback phase shift to obtain the rate-of-closure indicator. Rather than computing phase shifts from slopes, you can use this indicator to deal with the slopes directly. Rate-of-closure is simply the difference in slopes of the gain-magnitude curve and the $1/\beta$ curve when they intercept. This difference reflects the combined phase shift around the feedback loop. For Figure 1, the rate-of-closure is 20dB/decade , which corresponds to a stable 90° phase shift.

In other cases, the slope of the $1/\beta$ curve is not zero, giving a 40dB/decade rate-of-closure that indicates an oscillatory 180° of phase shift. Rate-of-closure alone is an exact stability indicator where the intercept is at least one decade away from all other break frequencies. In still other cases, the Bode phase approximation modifies the rate-of-closure result.

FEEDBACK FACTOR IS A VOLTAGE DIVIDER RATIO

To use feedback relationships to perform circuit analysis, you should consider the feedback network separately. This separation parallels the nature of the op amp's open-loop gain, which is a characteristic of the amplifier in the absence of the feedback network. You only need to retain the loading effects between the amplifier and the feedback network to determine their individual responses⁽²⁾. Then, by putting the two responses on the same plot, you can see how they will work together.

Figure 2 shows a generalized feedback condition defined by Z_1 and Z_2 . The equations of Figure 2a directly determine the circuit response for high loop gain and moderate impedances. Nonetheless, the input impedance of the amplifier alters the simplified results of these equations by shunting the feedback network. The inclusion of this loading effect on the feedback network completes the $1/\beta$ analysis in the circuit of Figure 2b. Here, the op amp input resistance (R_i), differential input capacitance (C_{id}), and common-mode input capacitance (C_{icm}) all shunt impedance Z_1 . Except for conditions where the feedback impedances have low values, you need to include these amplifier characteristics in your analysis.

Where there is impedance in series with the amplifier's noninverting input, you must add this too-along with the shunting effect of the input's C_{icm} capacitance. You can then find the feedback factor from the divider action, e_j/e_o . For the $1/\beta$ curve, this result is inverted and, in the logarithmic format of computer simulations, becomes simply

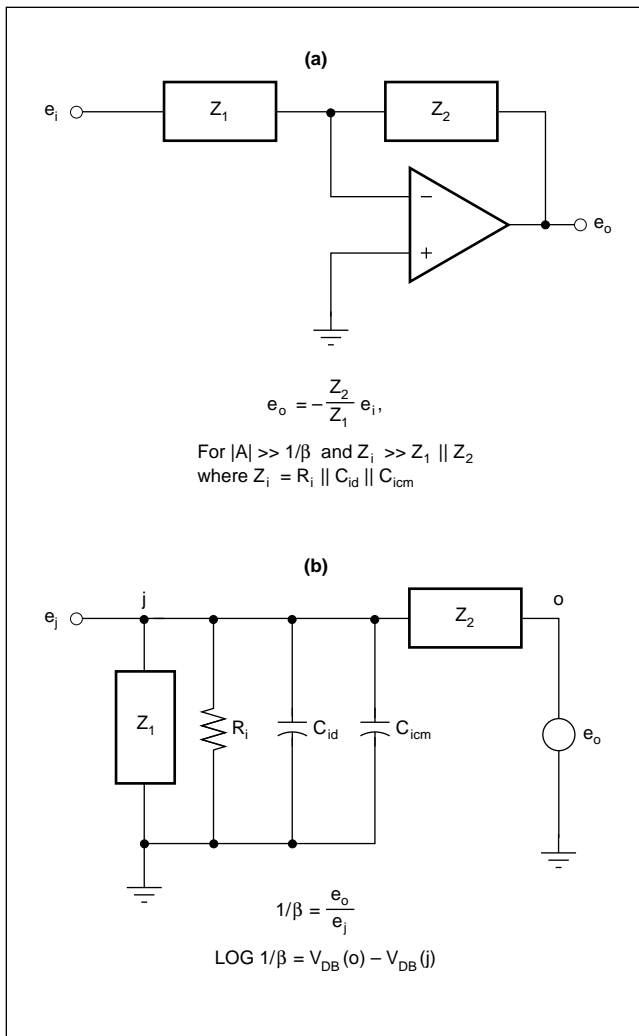

FIGURE 2. To determine the $1/\beta$ curve for the generalized circuit of (a), you can draw a voltage-divider circuit that represents the feedback network and the shunting effects of the amplifier input (b).

$V_{\text{DB}}(o) - V_{\text{DB}}(i)$. By adding this curve to the plot of the amplifier's gain-magnitude response, you can display the characteristics of the critical intercept for subsequent feedback interpretation.

NOISE GAIN AND $1/\beta$

The $1/\beta$ curve also communicates performance information across the entire response range of the op amp. For example, it displays loop gain, which provides an indication of gain accuracy vs frequency and the ultimate bandwidth limit. Furthermore, the $1/\beta$ curve demonstrates that the circuit's signal bandwidth can be different from its noise bandwidth. Note that the previous feedback-network analysis returns Z_1 to ground as it would in a noninverting op amp configuration, even though the op amp shown is in the inverting mode.

Underlying the difference between noise and signal bandwidth is the concept of noise gain, which is the source of some of the more common op amp application problems.

For any given feedback network, the inverting and noninverting configurations develop signal gains that differ in magnitude as well as in sign; nevertheless, the feedback conditions remain the same. In both cases, your feedback analysis is concerned with the gain-error voltage developed between the op amp inputs. This error signal always receives the gain of the noninverting connection, as you would see if you performed superposition analysis. Superposition of the signal between the amplifier inputs grounds the signal source, producing the noninverting configuration.

The same condition holds true for the input voltage noise of an op amp, resulting in the noise-gain characteristic for the $1/\beta$ curve. In practice, the noise gain and the $1/\beta$ curve are the same—until they intercept with the gain-magnitude curve. After that, the noise gain rolls off with the amplifier open-loop response but the $1/\beta$ curve continues on its path. For the noninverting voltage amplifier, the noise gain and the closed-loop gain, A_{CL} , are the same.

NOISE BANDWIDTH

In inverting configurations, this correspondence does not hold true, giving rise to frequent surprises during attempts at noise filtering. The simplest case of the inverting amplifier, where it is common practice to bypass the feedback resistor, serves to illustrate the inverting relationship (Figure 3). Bypassing the feedback resistor is intended to limit noise bandwidth, and it does indeed remove noise presented as an input signal. However, the circuit will continue to pass amplifier noise across the entire op amp bandwidth. C_f shunts the signal supplied through R_f for the desired lowpass roll-off of the op amp's e_o/e_i response. To the op amp noise voltage, e_n , C_f merely presents the unity feedback of a voltage-follower. Noise gain drops to unity but continues out to the open-loop roll-off of the op amp. This leveling off of $1/\beta$ also shows why the op amp must be unity-gain stable, even though the circuit gain has been rolled off well below the amplifier response. With $1/\beta$ following the unity gain axis, the critical intercept occurs at f_c .

While the continued noise gain is at a lower level, it covers much of the amplifier bandwidth, which can result in a dramatic increase in output noise. For example, if you're using the 2MHz Burr-Brown OPA111 shown and choose C_f to obtain a 2kHz roll-off, only 0.1% of the amplifier bandwidth will be enclosed in the intended system response. Although the logarithmic scale of the frequency axis may be visually deceptive, the remaining 99.9% of the bandwidth is still available to the amplifier's voltage noise. For an initial gain of 10, the output noise that this amplifier produces is more than doubled by the bandwidth effect. Many active-filter configurations are subject to the same limitation.

The only way to avoid excessive noise bandwidth is to restrict the frequency range of the op amp. By doing so, the control of the noise response switches from the $1/\beta$ curve to the amplifier roll-off. Where the op amp has provision for external phase compensation, this control is a simple matter and permits you to remove bandwidth from signal and noise

alike. However, because most op amps lack an external-phase-compensation facility, passive filtering within the feedback loop offers a broader solution⁽³⁾. Such filtering introduces a capacitive shunt to ground following the amplifier but within the feedback loop.

You can also demonstrate the extended noise bandwidth of an integrating converter using a feedback plot but, more importantly, the curves illustrate the dynamic-range limit for integrator-based instrumentation. In Figure 4, the integrator $1/\beta$ curve also levels off at the unity-gain line for continued noise gain out to where the op amp rolls off. Be aware that this action has far less noise significance for the integrator because of its increasing gain at lower frequencies. Integrators designed for operation to 1kHz or even higher are generally unaffected by the added noise bandwidth.

Nevertheless, the feedback plot for the integrator demonstrates a unique bandwidth limitation involving two critical

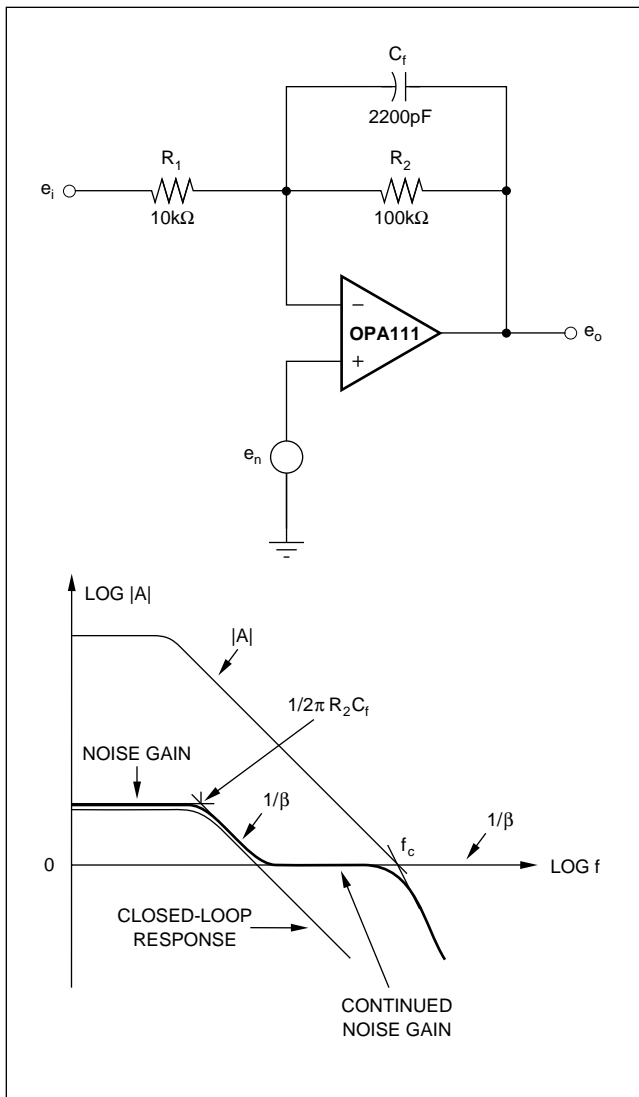

FIGURE 3. Highlighting the difference between closed-loop gain and noise gain, this inverting op amp configuration demonstrates the greater bandwidth that is often available to amplifier noise.

intercepts. Not only does the $1/\beta$ curve intercept the gain-magnitude curve at the high-frequency extreme, but it does so at the low-frequency end as well. Each intercept indicates a lack of amplifier gain for support of the feedback and a departure from the ideal response. At the high end, the $1/\beta$ curve and noise-gain level off, leaving A_{CL} to continue as long as the loop gain lasts. Next, $1/\beta$ intercepts the gain-magnitude curve at f_c where the noise gain rolls off.

This intercept is a high-frequency 3dB point for the integrator response, which then usually rolls up rather than down. Upward response in this region is due to signal feedthrough caused by the feedback elements in the absence of loop control. At the lower frequencies, the increasing gain demand encounters the DC gain limit of the op amp. This intercept marks the second 3dB point for the integrator response, which sets the range for accurate performance. Both intercepts have a 20dB/decade rate-of-closure, indicating stable operation.

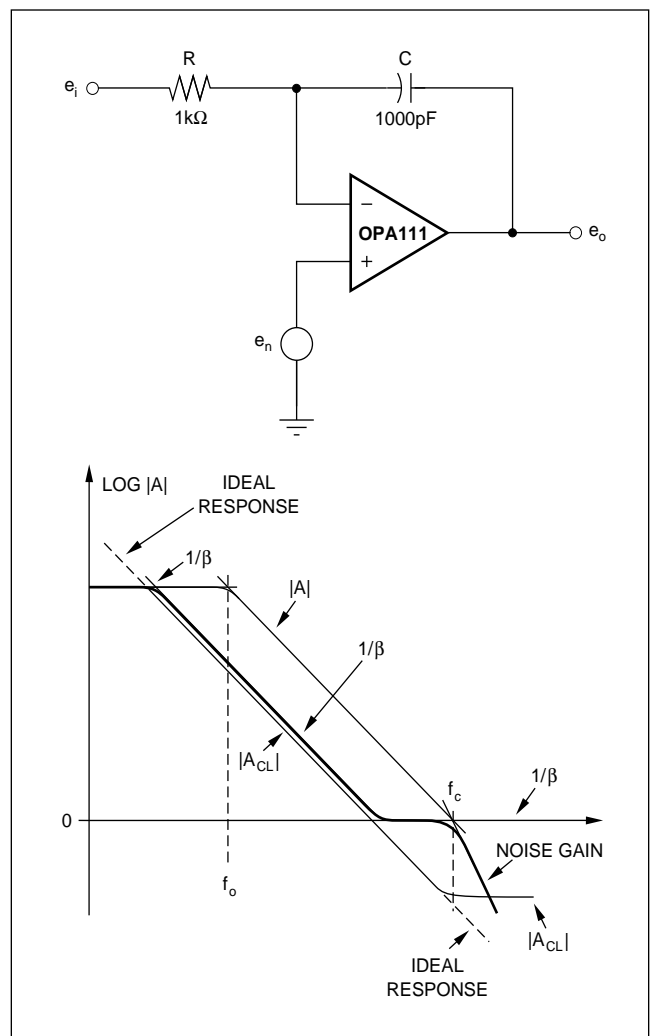

FIGURE 4. Defining the dynamic range for integrating data converters, the integrator $1/\beta$ curve displays upper and lower intercepts with the gain-magnitude response.

TWO BANDWIDTH LIMITS FOR INTEGRATORS

Between the two integrator-response limits is the usable dynamic range for dual-slope A/D and V/F converters. The gain error limits this dynamic range; the plots are a graphic representation of this error. The gain error is inversely related either to a circuit's loop gain or the difference between the amplifier's open-loop gain and the feedback demand of $1/\beta$. On the response plots, the loop gain is the vertical distance between the two curves. For the Figure 4 integrator, this separation decreases following $1/\beta$'s encounter with the unity-gain axis. From there, the separation finally reduces to zero at f_c . The gain error then becomes the distance between the dashed continuation of the ideal integrator response and the actual A_{CL} response. Graphically, this distance is the source of the large-signal limitation for integrating converters where higher signals correspond to the upper frequencies.

At the other end of the converter range, lower-level signals demand low-frequency integrator operation that encounters a similar limitation. Below the frequency of the op amp's first pole, f_o , the separation between the $1/\beta$ and gain-magnitude curves again drops, signaling reduced loop gain. Moving further down in frequency, the $1/\beta$ curve finally crosses the op amp's DC-gain level, and the actual response flattens again. For integrating-type converters, this action defines a range of performance that is accurate to within 3dB from f_c down to the lower intercept. To extend the dynamic range, you move the lower intercept downward either with a lower integrator-time-constant or with boosted DC gain.

A higher accuracy dynamic range results from the unique loop-gain conditions of the integrator. The loop gain is constant for the integrator from f_o to its unity-gain crossing. The gain error in this range is constant as marked by the uniform separation of the gain-magnitude and $1/\beta$ curves. You can compensate for such an error by making a fixed adjustment to the feedback network, leaving gain-accuracy bounded by the stability of the network. This limit permits you to adjust the more restricted dynamic range to 0.01% levels. For the OPA111 op amp and a 100kHz integrator crossover frequency, this more precise dynamic range has a span of 100,000:1.

INPUT CAPACITANCE ALTERS $1/\beta$

The previous discussion of the inverter and the integrator considered the feedback network independent of the amplifier input shunting. Although engineers frequently use this simplification, they often encounter unexpected results. Because of the feedback factor, most first-time users of op amps with large feedback-resistance values are surprised by the response curve. Transient-response ringing or even oscillation sometimes occurs; the common cure is a capacitive bypass of the feedback resistor. The $1/\beta$ curve can display the problem and provide some guidance in the selection of the bypass capacitor.

Underlying the problem is the op amp input capacitance's effect on the feedback factor. By including this capacitance

with the voltage divider formed by the feedback resistors, you can achieve the results of the $1/\beta$ curve in Figure 5. This curve rises at high frequencies, increasing the rate-of-closure and flagging the need for closer stability analysis. The phase margin drops as $1/\beta$ rises and, at the limit, goes to zero if the $1/\beta$ rise spans one decade of frequency. Generally, the span is much smaller than that and the Bode phase approximation evaluates the actual conditions. The key to minimizing the effect on the feedback factor is the low input capacitance that the small input FETs of the OPA128 device provide. The net 3pF of input capacitance leaves the response undisturbed until the parallel combination of the two resistors reaches 50k Ω .

The capacitive bypassing of R_2 increases the high-frequency feedback, which counteracts the shunting of C_{ia} by leveling off the $1/\beta$ curve. The selection of this capacitor is better illustrated by Figure 6's photodiode amplifier. You can reduce the non-obvious bandwidth of this application to an equation. The circuit contends with diode capacitances at the input up to 20,000pF. As a result, the break in the $1/\beta$ curve is generally far removed from the intercept, making the rate-of-closure analysis accurate without requiring any adjustment of the phase-shift approximation.

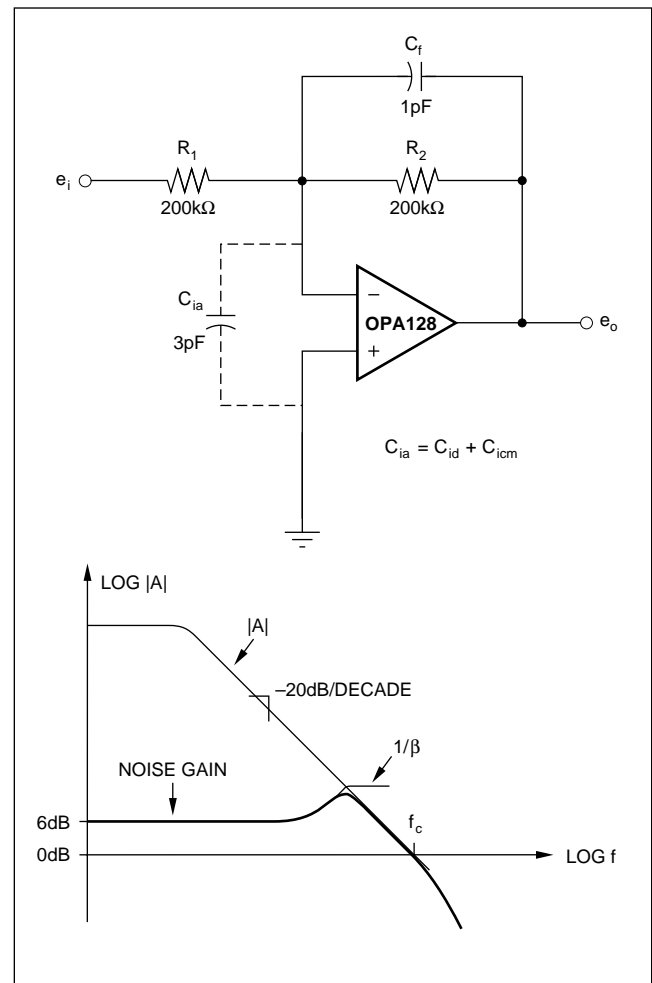

FIGURE 5. Higher feedback resistances will react with the op amp's input capacitance to produce a peaking effect, which the $1/\beta$ curve anticipates.

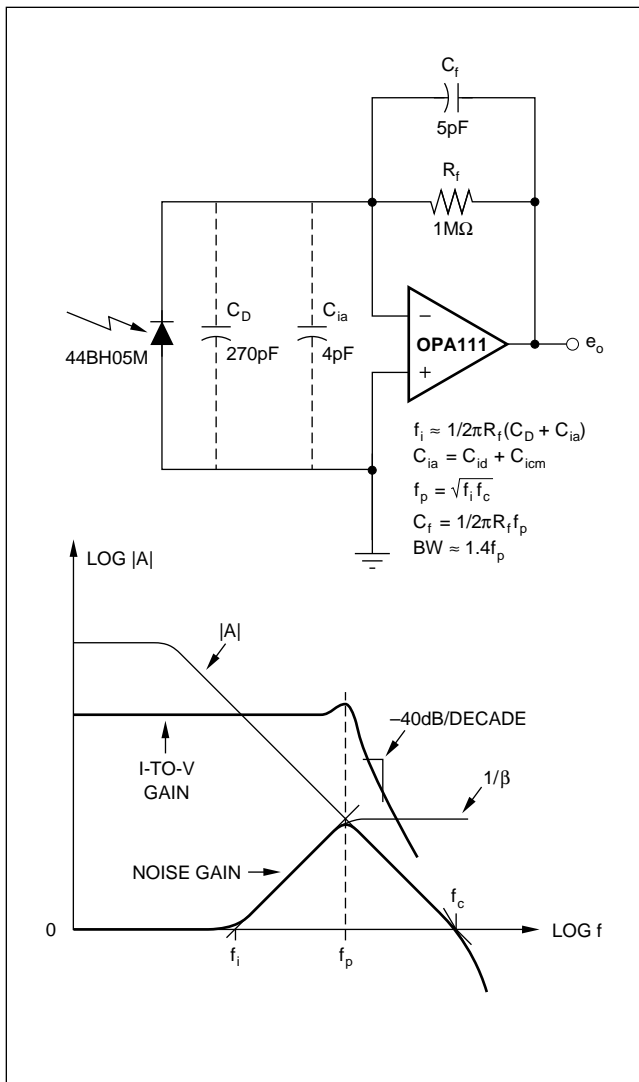

FIGURE 6. A photodiode amplifier's voltage function serves to obscure its bandwidth and stability, but you can rely on feedback-loop conditions to define its performance.

Unfortunately, the bandwidth for the circuit of Figure 6 is obscured by its function. Because its function is a current-to-voltage conversion, rather than simple voltage gain, you cannot draw the signal-gain curve on the gain-magnitude response to estimate bandwidth. When you inspect the circuit to find its bandwidth limitation, you'll see that the only inherent break frequency is that of the feedback resistance and the capacitance of the input circuit. By plotting the $1/\beta$ curve, however, you can see that the loop gain remains to support the ideal feedback condition far beyond the f_i break frequency.

Initially, the $1/\beta$ curve is flat at unity because of the direct output-to-input connection of R_f . When the feedback is later shunted by C_D and C_{ia} , $1/\beta$ rises at a 20dB/decade rate. The transition between these regions occurs at

$$f_i \approx 1/2\pi R_f (C_D + C_{ia})$$

where $C_{ia} = C_{id} + C_{icm}$.

The intercept with the gain-magnitude curve marks the end of the response rise for the noise gain. This curve has a -20dB/decade slope so, if left uncompensated, the rate-of-closure at the intercept will be 40dB/decade . Thus, the plot indicates two poles at that intercept frequency, f_p . This intercept is the point at which there is no longer sufficient amplifier gain for the feedback-factor demand, and it indicates response roll-off independent of the op amp function. Any amplifier function would then roll off with a slope equal to the rate-of-closure.

COMPENSATION BREAKS AT THE INTERCEPT

Because the rate-of-closure is 40dB/decade , you should examine phase shift at the intercept to determine the phase compensation necessary for stability. When the various break frequencies are well removed from the intercept, the rate-of-closure accurately reflects 180° of phase shift for the uncompensated loop. To avoid oscillation and to achieve good damping characteristics, you must reduce this phase shift by at least 45° through roll-off of the $1/\beta$ curve.

According to the Bode phase approximation, this phase shift is the amount of phase introduced at a break frequency. Choosing C_f to break with R_f at the intercept frequency, f_p , yields 45° of phase margin. Accompanying this phase condition is a 3dB peak in the signal response, which for a 2-pole response pushes the -3dB bandwidth out to $1.4f_p$. For the OPA111 and the feedback elements shown, the 3dB response extends to 48kHz. (You can extend this analysis to lower capacitance levels, and the common solution mentioned above will still suffice-even for the high-feedback-resistance case of Figure 5.)

As long as C_f breaks with R_f at the frequency of the intercept, the $1/\beta$ rise contributes no more than 45° of phase shift. In the range where the op amp phase shift is 90° , this rise leaves a stable 45° phase margin. Nevertheless, as the op amp approaches its crossover frequency, f_c , its contribution to phase shift moves toward 135° . The rule of thumb for selecting C_f remains valid, however, because any intercept near f_c must be a result of a $1/\beta$ rise of short duration. The added phase shift of the amplifier, accompanied by a necessary decrease in feedback phase shift at the intercept, results in a net zero effect. By simple sketching of the phase approximations for the $1/\beta$ and gain-magnitude curves, you can show this transition.

GEOMETRY DEFINES INTERCEPT

To select the compensation capacitance, it is desirable to reduce the graphical analysis to an equation. Luckily, the response plots provide an elegantly simple solution. Straight-line extensions of the $1/\beta$ and gain-magnitude curves form a triangle with the horizontal axis. These extensions have equal but opposite slopes, which form an isosceles triangle. The peak of the triangle, located over the center of its base, lies at the average of the base end points. Mathematically, this average point is equal to

$$\text{Log } f_p = (\text{Log } f_i + \text{Log } f_c)/2$$

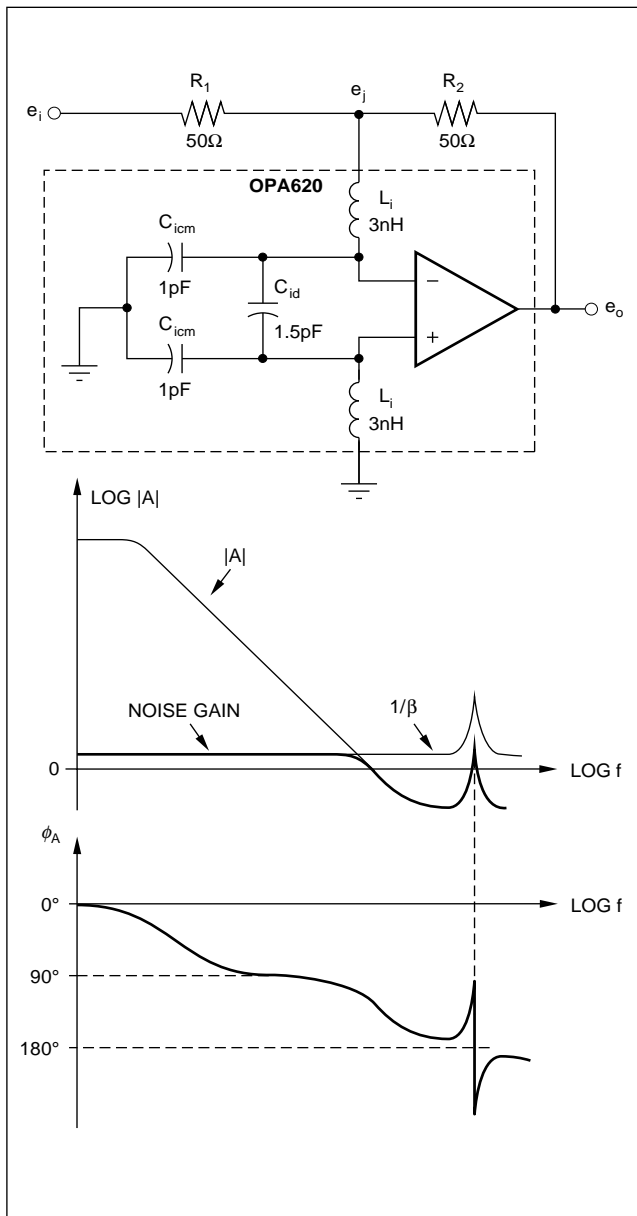

FIGURE 7. Although amplifier gain and phase plots suggest instability, the $1/\beta$ curve shows stable conditions for a circuit with input-lead inductance.

Given the expressed logarithmic nature of the frequency axis, you can reduce this relationship to the simple geometric mean of the two characteristic frequencies:

$$f_p = \sqrt{f_i f_c}$$

where $f_i = 1/2\pi R_f(C_D + C_{id} + C_{icm})$, and f_c equals the unity-gain bandwidth of the op amp.

GAIN AND PHASE CAN BE MISLEADING

For a third input-circuit effect, the $1/\beta$ curve demonstrates stable conditions where typical gain and phase plots would point to oscillation. In addition to input capacitance, op amps have input inductance; this combination produces a high-frequency resonance. The inductance is small but inescapable, being associated with internal input wires and being compounded by external wiring.

For very high-frequency amplifiers, like the OPA620 wideband amplifier of Figure 7, sufficient amplifier gain exists at the resonant frequency to give the appearance of zero gain margin. A comparison of the output signal (e_o) with that at the summing junction (e_i) produces the plot's gain and phase responses. Following unity crossover, the gain curve rises again above the unity axis; this rise generally guarantees oscillation for lower gain levels. Adding to stability concerns is the phase plot, which swings wildly through 180° during the gain peak.

By adding the $1/\beta$ curve to the plot, you can see that this curve does not intersect the gain peak but merely rides over it. Without an intercept there is no oscillation, regardless of the phase shift, because the loop gain is insufficient. Loop-gain demand rises in synchronization with the gain peak because the resonant circuit also alters the feedback network.

In many cases, the gain peaking results from conditions in the amplifier output rather than from the input circuit. In such a case, no corresponding modification of feedback occurs, and an intercept and oscillation result. However, for Figure 7, the gain margin remains high, as you can see by the separation between the $1/\beta$ curve and the gain response when the phase reaches 180° . This separation remains large throughout the region of higher phase shift, indicating good relative stability.

COMPOSITE AMPLIFIERS

Whereas the normal op amp feedback loop involves only one amplifier, designers often need to extend the feedback loop to work with composite circuits that use two or more op amps for increased gain. By adhering to conventional feedback principles, you can implement phase compensation for the extended loop and rely on a Bode plot to provide a visual representation of the increased gain and the opportunity for extended bandwidth.

For instance, with two op amps in the same loop as in Figure 8, you can achieve increased gain without incurring any added offset and noise error. The input-error effects of the second amplifier are divided by the open-loop gain of the first amplifier. The net open-loop gain of this composite circuit becomes the product of the individual op amp gains and greatly reduces the overall gain error and nonlinearity.

In Figure 8, the two op amps are those of the dual OPA2111, which imposes only a modest cost increase over a single device. You could, of course, select individual op amps to provide specific performance characteristics. In the latter case, you might select the input amplifier for good DC and noise performance and the output amplifier for its load-driving and slewing performance. For example, the output amplifier could handle the load current and the resulting power dissipation, thus producing no thermal feedback to the input of the composite circuit. Moreover, it could also fulfill the high-slew-rate demands of the application. The input amplifier in this case would only swing through small signals.

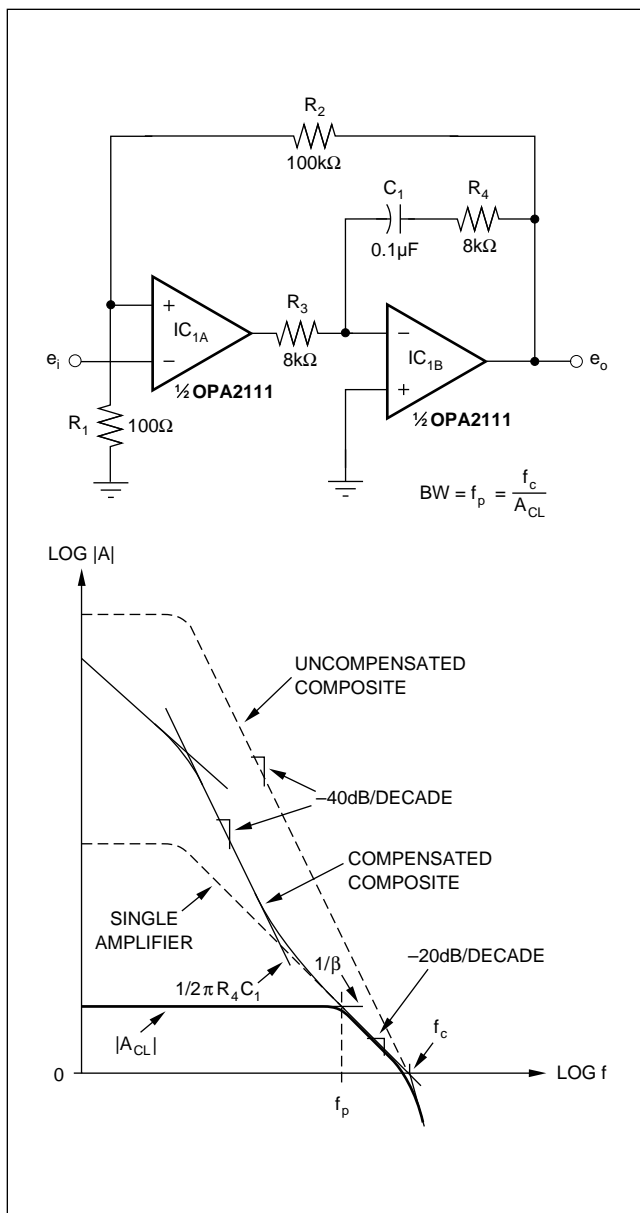

FIGURE 8. To utilize the boosted gain of the composite amplifier, traditional phase-compensation techniques tailor the gain-magnitude slope to obtain a stable region with a $1/\beta$ intercept.

An integrator and a common op amp test loop can demonstrate the benefits of using a composite amplifier. By extending the composite open-loop gain to higher levels, you can expand the dynamic range for integrating analog functions. The low-frequency intercept moves back by a factor equal to the added amplifier gain. This change is so extreme that other error effects will surface well before the gain error from the intercepts. For two op amps in the same loop each having 100dB open-loop gain, the composite gain is 200dB. At this gain level, an input error of 1nV will develop the full 10V output swing. Long before the circuit reaches that limit, noise becomes a prime AC constraint and typically restrains lower-level accuracy over a dynamic range of about

3,000,000:1. Nevertheless, this restraint is a 30:1 improvement over a single op amp and moves the focus of measurement accuracy to other factors.

In the op amp test-loop application⁽⁴⁾, the addition of the second amplifier removes signal swing from the output of the tested device. The extra gain transfers that voltage swing to an isolated output and removes any gain error from the signal detected at the tested amplifier's inputs. This gain-error removal permits the discernment of other input-error signals for the measurement of parameters such as power-supply and common-mode rejection. If these parameters were to approach the level of the amplifier's open-loop gain, gain-error signals at the input would cloud the effects of the measured parameter.

PHASE COMPENSATION FOR THE COMPOSITE AMPLIFIER

With a composite op amp structure, you must include the roll-off characteristics of both amplifiers in your AC analysis and have some means of providing phase compensation for the loop. Two op amps in a common loop invite oscillation; the individual amplifier poles combine for a composite 2-pole roll-off. As shown in Figure 8, the logarithmic scale makes the initial composite-response curve the linear sum of the two individual responses. The upper, dashed response curve, which has a -40dB/decade slope, shows this result.

Two methods are available for compensating the composite loop. One modifies the gain-magnitude response and the other alters the $1/\beta$ curve. The more usual of the two approaches is to reduce the slope of the gain-magnitude curve in the vicinity of the intercept, as Figure 8 does. After forcing the compensated response to roll off earlier, the gain-magnitude curve returns with a more gentle slope to the boundary of the uncompensated response. This action serves the general-purpose requirements of voltage-gain applications and produces a stable range that you can place almost anywhere in the total composite-gain range.

Figure 8 achieves this compensation by creating a modified integrator response for IC_{1B}. Because this integrator is an inverting circuit, the inputs of IC_{1A} are reversed to retain only one phase inversion in the loop. Capacitor C₁ blocks the local DC feedback, and the overall gain is still the product of the two open-loop gains. The integrator response that R₃ and C₁ established for IC_{1B} rolls off this composite gain. Next, the first open-loop pole of IC_{1A} returns the compensated response slope to -40dB/decade . At a higher frequency, a response zero provides the region of reduced slope thanks to the inclusion of R₄. Above the break frequency of R₄ and C₁, R₄ transforms the response of IC_{1B} from an integrator to an inverting amplifier with a gain of $-R_4/R_3$.

Where this gain is unity, the compensated response drops to and follows the open-loop response of IC_{1A} as shown. For gain levels other than unity, you have different options, which you can explore by using other response plots and defining the particular stable conditions you have in mind.

Having control of this gain becomes particularly useful as the $1/\beta$ intercept approaches the uncompensated unity-gain crossover point. In this region, the second poles of the two op amps increase the phase shift. In such cases, you have to make the magnitude of the internal R_4/R_3 gain less than unity to force the compensated response to cross over earlier. Generally, when you have two op amps of the same type, making $R_4 = R_3/3$ will yield a unity-gain stable composite amplifier.

The net phase correction that you can achieve with this technique depends on the frequency-response range for which you maintain the -20dB/decade slope. This span begins with the R_4C_1 break frequency and ends with the intercept of the composite open-loop response. After this intercept, the lack of open-loop gain returns the response to that of the uncompensated composite amplifier. To ensure a phase margin of 45° or more, you can use the guidance that the Bode phase approximation provides; the plot shows that this reduced slope region must last for three decades of frequency and must intercept the $1/\beta$ curve after running for at least a decade.

COMPOSITE AMPLIFIERS EXTEND BANDWIDTH

Although most engineers are familiar with this type of phase compensation, it is too restrictive of bandwidth at higher gains. For applications requiring higher gains, you can greatly extend the bandwidth and reduce the settling time by 40:1 by using a different phase-compensation technique. The general-purpose $R_4 = R_3$ case of Figure 8 sets a constant closed-loop gain-bandwidth product. Looking at the curves, you can see that the closed-loop bandwidth is the same as that for IC_{1A} itself when $BW = f_p = f_c/A_{CL}$. Even so, the large separation between the compensated and uncompensated responses shows a significant sacrifice in bandwidth—expressly for the accommodation of phase compensation. Uncompensated, the gain-magnitude response has a gain-bandwidth product that increases with closed-loop gain and that provides a potential bandwidth of $f_p = f_c/\sqrt{A_{CL}}$. Comparing the last two expressions shows that the potential for bandwidth improvement equals $\sqrt{A_{CL}}$, which is significant at higher gains.

COMPENSATE THE $1/\beta$ CURVE

You can take advantage of quite a bit of this bandwidth-improvement opportunity by compensating the $1/\beta$ curve instead of the gain-magnitude response curve. By referring back to the rate-of-closure stability criteria discussed previously, you would see that both curves contribute to the rate-of-closure parameter even though the gain-magnitude curve is generally the focus of phase-compensation efforts. To satisfy the rate-of-closure criteria, all that is necessary is to control the difference between the slopes, regardless of the slopes of the individual curves. So, instead of reducing the gain-magnitude slope, increase the $1/\beta$ slope (Figure 9). A simple capacitive bypass of feedback resistor R_2 accomplishes this slope increase for a final 20dB/decade rate-of-closure.

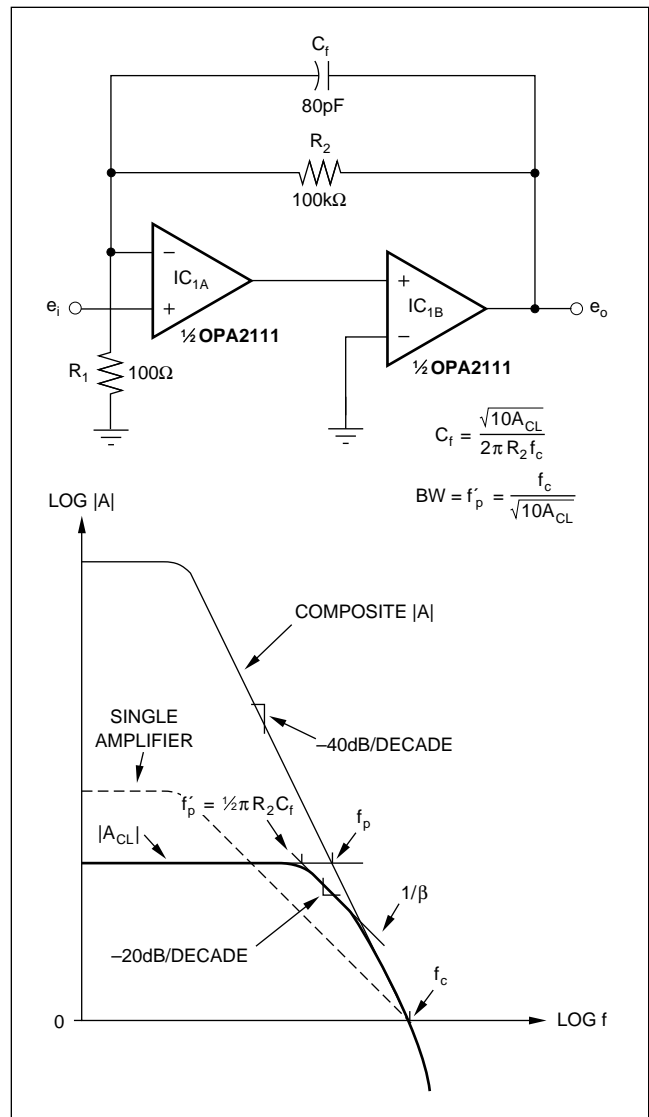

FIGURE 9. For greater bandwidth in high-gain circuits, you can provide phase compensation for the $1/\beta$ response to retain a smooth open-loop response for fast settling.

An integrator configuration, on the other hand, with its special characteristics, inherently produces the -20dB/decade slope for $1/\beta$ and achieves optimum bandwidth and dynamic range.

Two factors distinguish this feedback-factor compensation technique for higher gains. Greater bandwidth is open for reclaiming, and the associated $1/\beta$ curves are well above the unity-gain axis. From higher levels, the $1/\beta$ roll-off is developed well before its intercept with the gain-magnitude curve. Starting this roll-off a decade ahead of the final intercept produces a 45° phase adjustment for a like amount of phase margin. The slopes of the two curves show that, in order to accomplish this phase adjustment, C_f must break with R_2 one-half decade below the initial intercept frequency, f_p . Then, the 2:1 difference in slopes will place the new intercept one-half decade above f_p for the required full decade of the $1/\beta$ roll-off.

CHOOSING C_f FOR THE COMPOSITE AMPLIFIER

Again, the design equations for the required value of C_f and the resulting bandwidth are obvious from the logarithmic nature of the frequency axis. Setting f_p' at one-half decade below f_p implies that

$$\text{Log } f_p' = (\text{Log } f_p + \text{Log } f_p/10)/2$$

for which $f_p' = f_p/\sqrt{10}$. From before, you'll remember that $f_p = f_c/\sqrt{A_{CL}}$ describes the uncompensated curve's bandwidth. The compensated bandwidth is

$$\text{BW} = f_p' = f_c/\sqrt{(10A_{CL})}$$

Here, f_c is the unity-gain crossover frequency of the composite gain-magnitude response. As becomes obvious when you examine this expression, the improved bandwidth falls short of the total potential by $\sqrt{10}$. However, it is better than the Figure 8 result by $\sqrt{(A_{CL}/10)}$, or a factor of 10, for a gain of 1000. Setting C_f to break with R_2 at f_p' defines the value of this capacitor as

$$C_f = \sqrt{(10A_{CL})/2\pi R_2 f_c}$$

For the op amps of the dual OPA2111 shown, the gain-of-1000 bandwidth becomes 20kHz as compared with the 2kHz you'd realize if you used just one of the op amps.

COMPOSITE COMPENSATION EFFECTS

Settling time also improves when you choose the composite amplifier's $1/\beta$ curve for phase compensation. The improvement is a result of both the increased bandwidth and the retained constant gain-magnitude slope. For a single amplifier of the OPA2111 type, for a gain of 1000, the settling time would be 700 μ s to 0.01%. Because the Figure 9 amplifier has 10 times the bandwidth of a single amplifier, the settling time drops by the same factor to 70 μ s. This improvement would not be possible without the smooth and continuous slope of the compensated-amplifier response. A response having an intermediate pole and zero, such as Figure 8 does, has low-frequency response terms that are slow to settle following a transient. Known as an integrating frequency doublet, this pole/zero combination is notorious for its poor settling time⁽⁵⁾. By providing phase compensation for the $1/\beta$ curve, you ensure that the smooth gain-magnitude curve is left undisturbed, therefore achieving the optimum settling time.

At lower gains, the benefit of the $1/\beta$ compensation technique diminishes as does its control of phase. Because lower gains have $1/\beta$ curves closer to the unity-gain axis, they have less room for $1/\beta$ roll-off. To produce an intercept with the gain-magnitude curve after a decade of $1/\beta$ roll-off requires a minimum closed-loop gain of 10. Op amp phase shifts impose further limits by growing from 90° to 135° as they approach the unity-gain crossover frequency. In the practical case, this phase-compensation method needs gains of 30 or more for good stability.

This type of phase compensation does have an unusual aspect: Too great a compensating capacitance will have a surprising effect. Whereas increasing such capacitance normally yields more damping and a more stable response,

making C_f too large will cause instability. As C_f increases, the resulting intercept moves toward f_c and encounters the added phase shift of the secondary-amplifier poles. Even greater values of C_f will drop the $1/\beta$ curve to its limit at the unity-gain axis. From there, it proceeds along the axis to the magnitude-curve intercept that guarantees oscillation. Only a range of compensation-capacitor values provides stability with this second approach; the $1/\beta$ curves display this range for sensitivity-analysis purposes. Because of the capacitor's window of stable values, a random selection of C_f followed by a stability test is likely to miss the bandwidth opportunity of this technique.

PHASE ONLY MATTERS AT THE INTERCEPT

Another concept fundamental to op amp feedback in composite-amplifier circuits becomes apparent when you examine phase shift and stability. Composite amplifiers such as the one in Figure 10 produce a -40dB/decade slope over wide ranges both before and after the $1/\beta$ intercept. Because this slope corresponds to a 180° phase shift, frequent concern over stability conditions arises at points other than that of the critical intercept. Beyond the $1/\beta$ intercept, the loop gain is less than 1 and therefore it is easy to see that the circuit cannot sustain oscillation. Yet, prior to the intercept, the gain of the feedback loop is very high and would seem capable of causing the circuit to oscillate.

In reality, the high loop gain is a protection against, rather than a promoter of, oscillation. Sustained oscillation depends on the op amp's gain-error signal. In Figure 10, the gain error, e_o/A , appears between the op amp inputs and receives amplification from the closed-loop gain, A_{CL} . Here, A_{CL} is that of the noninverting configuration, the noise gain that reacts with any input-referred error signal. To sustain oscillation, the amplified error signal must independently deliver the output signal. This action requires that $(-e_o/A)A_{CL} = e_o$. Note that e_o appears on both sides of this equation; it should therefore be obvious that any solution must conform to very specific constraints. This equation expresses both polarity and magnitude constraints; the composite amplifier's 180° phase shift satisfies the sign change.

For the magnitude constraint, two possible solutions exist. The first is $e_o = 0$, which is the stable state for the composite amplifier in the questioned region. There, the loop gain makes the signal e_o/A too small to independently support an output signal. In the plots of Figure 10, e_o/A starts at a very low level due to the high loop gain at low frequencies. As you move up in frequency, the gain-error signal rises while the amplifier-response slope signals its polarity inversion through the 180° phase shift. This inversion increases the output signal but cannot sustain it until the gain-error signal reaches a sufficient level. This critical level is a prerequisite for oscillation.

This level applies to the second solution for the magnitude constraint. At this level, A/A_{CL} has unity magnitude and maintains the balance for the previous feedback equation's magnitude requirement. Unity loop gain occurs at the $1/\beta$

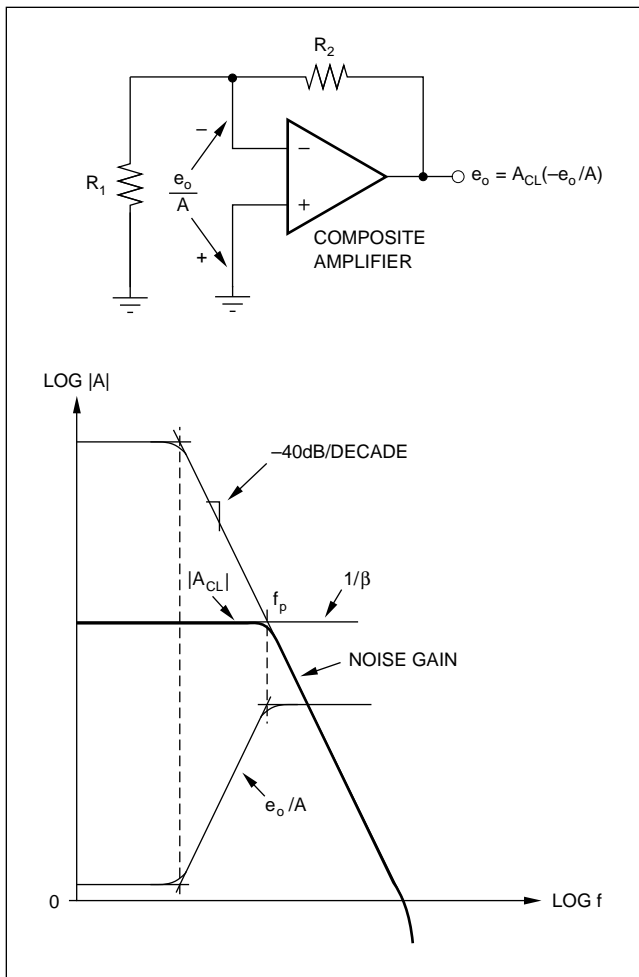

FIGURE 10. A phase shift of 180° causes oscillation only where the gain-error, e_o/A , is capable of independently supporting the output signal.

intercept where the open-loop and noise-gain curves meet. Without phase-compensation intervention, this intercept satisfies both the phase and magnitude requirements for oscillation. Beyond this point, e_o and A fall off together, leaving the e_o/A signal constant and unable to support oscillation with the reduced gain. At the point where the magnitude of the gain error and the feedback phase shift must both reach specific levels to support oscillation, the intercept becomes critical. Before or after the intercept, the loop phase shift can be at any level and the gain-error magnitude will not be sufficient to cause instability.

Unfortunately, despite the composite amplifier's very specific requirements for oscillation, the greatly varied applications of op amps make this critical condition all too easy to encounter. To contend with this problem, you can rely on the $1/\beta$ curve to present a visual prediction of the problem and provide insight into a solution.

ACTIVE FEEDBACK VARIES $1/\beta$

Some applications demand that you include a second active element in the feedback loop to produce a varying feedback factor. In these applications, both the magnitude and the

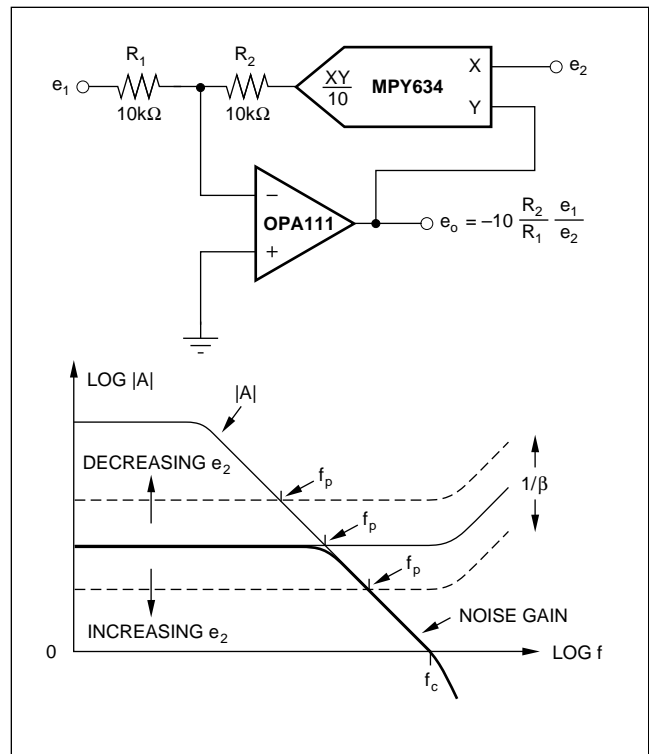

FIGURE 11. For this common analog divider, a variable feedback magnitude allows a range of conditions that define bandwidth and stability.

frequency characteristics of $1/\beta$ become variables. Fortunately, the gain- and feedback-response curves offer a means of quickly evaluating the range of conditions resulting from the changing feedback.

The most common way to provide magnitude variation in the feedback factor is to use a low-cost analog divider realization. Placing a multiplier in the feedback loop of an op amp (Figure 11) makes feedback a function of a second signal and therefore produces divider operation. With signal dependent feedback, the bandwidth and stability conditions also become variables.

Figure 11 shows the divider connection⁽⁶⁾ and demonstrates the effect of voltage-controlled feedback on $1/\beta$. The amplifier's feedback inverts the function of the multiplier by placing the feedback signal under the control of the e_2 signal. Then, the multiplier's transfer function of $XY/10$ delivers $e_o(e_2/10)$ to R_2 . This action scales the feedback signal by comparing e_2 to 10V reference level to obtain

$$\beta = (e_2/10) R_1/(R_1 + R_2)$$

With the feedback factor under control of this signal, the $1/\beta$ curve moves across the full range of the gain-magnitude response. As e_2 nears zero, the $1/\beta$ curve approaches infinity, leaving the op amp essentially in an open-loop configuration. At the other extreme, a full-scale 10V value for e_2 delivers a feedback signal to R_2 that equals e_o almost as if the multiplier were not present. Then, the net response is that of a simple inverting amplifier with a feedback factor of $R_1/(R_1 + R_2)$ and an inverting gain of $-R_2/R_1$.

INTERCEPT VARIES WITH $1/\beta$

Between the extremes, the variation of e_2 moves the $1/\beta$ curve from as low as the unity-gain axis to above the upper reaches of the amplifier's gain-magnitude curve. This variation moves the critical intercept and requires attention to the rate-of-closure over the entire span of the gain-magnitude response. If no significant multiplier phase shift exists, the feedback will always resemble that of an inverting amplifier for a zero $1/\beta$ slope, and you can ensure stability by just using a unity-gain-stable op amp. You can then read the range of bandwidth for the divider operation directly from the moving $1/\beta$ intercept. For a given e_2 range, the intercept moves linearly with the signal, defining the corresponding bandwidth range.

The multiplier also introduces phase shift that alters the net phase shift around the feedback loop. Poles in the response of the multiplier circuit are zeros in the inverse $1/\beta$ function, causing the curve to rise at high frequencies. This rise moves toward the critical intercept when the multiplier control voltage, e_2 , increases. This rise has an impact on the rate-of-closure, and the op amp must introduce a dominant pole to maintain stability. For the components shown, the OPA111 dominates the circuit roll-off because of its 2MHz unity-gain crossover frequency. This frequency is well below the 10MHz bandwidth of the MPY634 multiplier, placing the op amp in control. Other options that use a separate feedback path to restrict the op amp bandwidth are also available⁽³⁾.

VARIABLE $1/\beta$ FREQUENCY RESPONSES

Other ways of providing variable feedback are also available. For example, you can have the signal control the frequency—rather than the magnitude—characteristics of the feedback. The result is a variable slope at the intercept, as is the case with the voltage-controlled lowpass filter in Figure 12. The basic elements of the lowpass filter are the op amp, the resistors, and the capacitor. If you replace the multiplier with a short circuit, these elements form a fixed-frequency roll-off. Essentially, this shorted condition is established when $e_2 = 10V$ and when the gain through the multiplier is unity. Capacitor C_1 then breaks with R_2 to define the filter roll-off just as if the resistor and capacitor were directly in parallel.

For levels of e_2 below full scale, the multiplier serves as a voltage-controlled attenuator to effectively alter the filter time constant. Attenuating the feedback voltage to R_2 lowers the signal current to the summing node, which has the same effect as increasing the resistor's value. Increased effective resistance corresponds to a decrease in the resistor's break frequency with C_1 . This break defines the variable filter roll-off when

$$f_p = e_2/20\pi R_2 C_1$$

The maneuvering of the $1/\beta$ curve through this operation deserves closer inspection. The circuit exhibits a signal-dependent transition between the two different loops, which alternately control the feedback. At low frequencies, C_1 is effectively an open circuit, and the controlling feedback path

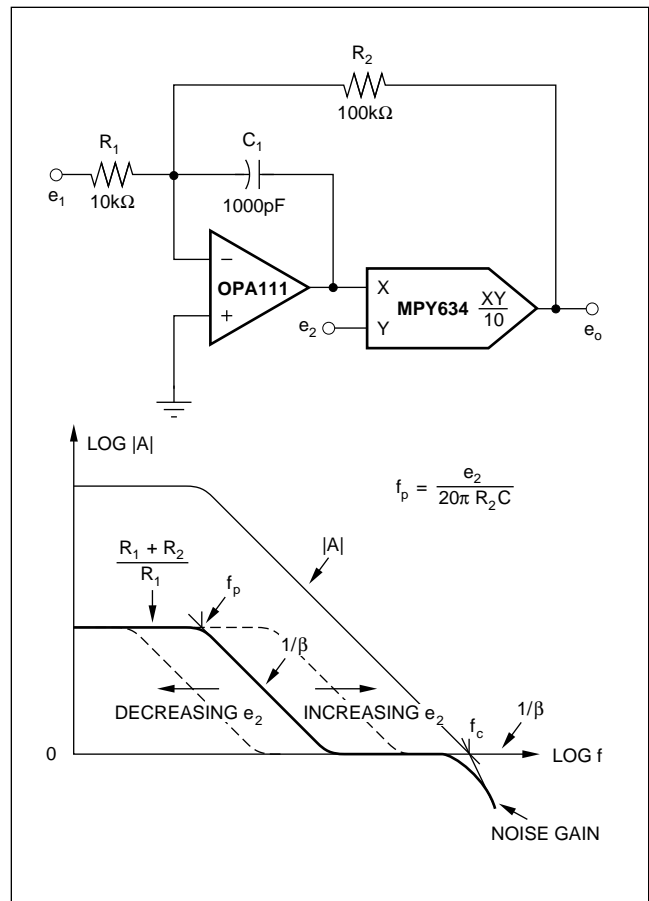

FIGURE 12. In this filter circuit, variations in the frequency characteristic of $1/\beta$ make possible a changing $1/\beta$ slope at the intercept.

is through the op amp and the multiplier. This composite structure has resistive feedback that defines a signal gain of $-R_2/R_1$ and a noise gain of $(R_1 + R_2)/R_1$. The latter relationship equals $1/\beta$ at low frequencies and the curve of interest starts at this level with a zero slope. At the high-frequency end, the composite structure is overridden when C_1 acts as a short circuit, which results in a unity feedback factor around the op amp. This short circuit absorbs all feedback current from R_2 without any corresponding change in the amplifier output voltage. The feedback loop of the composite structure is then disabled, switching feedback control to just the op amp. With C_1 then providing a unity feedback factor to the op amp, the $1/\beta$ curve follows the unity-gain axis at high frequencies.

Once the $1/\beta$ levels are fixed at the extremes, the multiplier determines the nature of the transition between the two. In the transition region, feedback currents from R_2 and C_1 compete for control of the summing node of the op amp input. The contest for dominance is analogous to the frequency-dependent control of impedance with a parallel RC circuit. In both cases, the 3dB point, where each element carries the same magnitude of current, defines the transition of control. The Figure 12 filter achieves equal element currents when the impedance of C_1 and the effective impedance of R_2 are equal. This equality defines the voltage-

controlled roll-off frequency of the filter as previously expressed. At this frequency, $1/\beta$ also rolls off and drops at -20dB/decade to the high-frequency limit of the unity-gain axis.

RATE-OF-CLOSURE VARIES WITH $1/\beta$

The stability conditions of the Figure 12 circuit depend on the particular feedback loop or the combination of elements that are in control at the intercept point. For the lower-frequency filter cutoff frequencies illustrated, the op amp's bypass capacitor takes control before the intercept and defines the relevant feedback conditions. Because the $1/\beta$ curve follows the unity axis at the upper end, you can guarantee stability by ensuring that the op amp be unity-gain stable. For higher-frequency cutoff frequencies, the $1/\beta$ transition moves toward the gain-magnitude curve of the op amp. Circuit response cannot move beyond this limit, so the op amp roll-off becomes the upper boundary of filter operation.

When the cutoff frequency approaches this boundary, the intercept rate-of-closure varies, prompting stability analysis. First, the zero of the $1/\beta$ curve approaches the intercept, where it increases the slope of the curve. Because this action reduces the rate-of-closure, stability is improved and a more detailed analysis is unnecessary. A continued increase in the cutoff frequency moves the $1/\beta$ curve further to the right where its pole interacts at the intercept. This break frequency returns the rate-of-closure to 20dB/decade , thus retaining stability. Beyond this point, the intercept occurs at the flat lower end of the $1/\beta$ curve, and no further change in the rate-of-closure takes place.

Utilizing these various feedback conditions and a unity-gain-stable op amp, you can design a composite circuit that fulfills its primary stability requirement over the entire

operating range. In addition, however, you may sometimes require a multiplier having a bandwidth much greater than that of the op amp, as the two previous examples demonstrate. Without a wide-bandwidth multiplier, $1/\beta$ would begin to rise near the higher-frequency intercepts and increase the rate-of-closure. The OPA111 avoids this complication when using the MPY634 multiplier by maintaining a dominant op amp pole.

Other applications may involve feedback peaking and op amps that are not unity-gain stable-log amps and active filters, for example. For these and other variations requiring feedback analysis, the test remains the same. Look for the critical condition where the rate-of-closure is 40dB/decade . Where conditions approach this level, conduct further analysis and compare phase-compensation alternatives for optimization.

REFERENCES

1. Tobey, G. E., Graeme, J. G., and Huelsman, L. P., *Operational Amplifiers: Design and Applications*, McGraw-Hill, 1971.
2. Bower, J. L., and Schultheis, P. M., *Introduction to the Design of Servomechanisms*, Wiley, 1961.
3. Stitt, R. M., and Burt, R. E., "Möglichkeiten zur Rauschunter-druckung," *Elektronik*, December 1987, pg 112.
4. Lewis, E. D., "Compensation of Linear IC Test Loops," *Electronics Test*, May, 1979, pg 83.
5. Dostal, E. J., *Operational Amplifiers*, Elsevier Scientific Publishing, Amsterdam, Holland, 1981.
6. Wong, Y. J., and Ott, W. E., *Function Circuits: Design and Applications*, McGraw-Hill, New York, NY, 1976.

IMPORTANT NOTICE

Texas Instruments and its subsidiaries (TI) reserve the right to make changes to their products or to discontinue any product or service without notice, and advise customers to obtain the latest version of relevant information to verify, before placing orders, that information being relied on is current and complete. All products are sold subject to the terms and conditions of sale supplied at the time of order acknowledgment, including those pertaining to warranty, patent infringement, and limitation of liability.

TI warrants performance of its semiconductor products to the specifications applicable at the time of sale in accordance with TI's standard warranty. Testing and other quality control techniques are utilized to the extent TI deems necessary to support this warranty. Specific testing of all parameters of each device is not necessarily performed, except those mandated by government requirements.

Customers are responsible for their applications using TI components.

In order to minimize risks associated with the customer's applications, adequate design and operating safeguards must be provided by the customer to minimize inherent or procedural hazards.

TI assumes no liability for applications assistance or customer product design. TI does not warrant or represent that any license, either express or implied, is granted under any patent right, copyright, mask work right, or other intellectual property right of TI covering or relating to any combination, machine, or process in which such semiconductor products or services might be or are used. TI's publication of information regarding any third party's products or services does not constitute TI's approval, warranty or endorsement thereof.