

Feedback Amplifiers

Collection of Solved Problems

A collection of solved feedback amplifier problems can be found at the below link. The solutions are based on the use of the Mason Flow Graph described below.

<http://users.ece.gatech.edu/~mleach/ece3050/notes/feedback/FBExamples.pdf>

Basic Description of Feedback

A feedback amplifier is one in which the output signal is sampled and fed back to the input to form an error signal that drives the amplifier. The basic block diagrams of non-inverting and inverting feedback amplifiers are shown in Fig. 1. Depending on the type of feedback, the variables x , y , and z are voltages or currents. The diagram in Fig. 1(a) represents a non-inverting amplifier. The summing junction at its input subtracts the feedback signal from the input signal to form the error signal $z = x - by$ which drives the amplifier. If the amplifier has an inverting gain, the feedback signal must be added to the input signal in order for the feedback to be negative. This is illustrated in Fig. 1(b). The summing junction at the input adds the feedback signal to the input signal to form the error signal $z = x + by$. In both diagrams, the gain around the loop is negative and equal to $-bA$, where both A and b are positive real constants. Because the loop-gain is negative, the feedback is said to be negative. If the gain around the loop is positive, the amplifier is said to have positive feedback which causes it to be unstable.

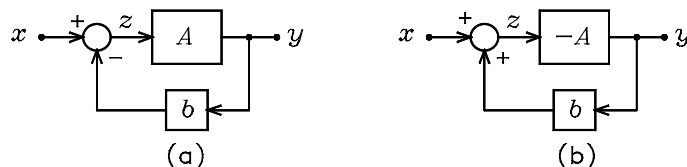

Figure 1: Feedback amplifier block diagrams. (a) Non-inverting. (b) Inverting.

In the non-inverting amplifier of Fig. 1(a), the error signal is given by $z = x - by$. The output signal can be written.

$$y = Az = A(x - by) \quad (1)$$

This can be solved for the gain to obtain

$$\frac{y}{x} = \frac{A}{1 + bA} \quad (2)$$

We see that the effect of the feedback is to reduce the gain by the factor $(1 + bA)$. This factor is called the “amount of feedback”. It is often specified in dB by the relation $20 \log |1 + bA|$.

In the inverting amplifier of Fig. 1(b), the error signal is given by $z = x + by$. When x goes positive, y goes negative, so that the error signal represents a difference signal. The output signal can be written

$$y = -Az = -A(x + by) \quad (3)$$

This can be solved for the gain to obtain

$$\frac{y}{x} = \frac{-A}{1 + bA} \quad (4)$$

We see that the amount of feedback for the inverting amplifier is the same as for the non-inverting amplifier.

If A is large enough so that $bA \gg 1$, the gain of the non-inverting amplifier given by Eq. (2) can be approximated by

$$\frac{y}{x} \simeq \frac{A}{bA} = \frac{1}{b} \quad (5)$$

The gain of the inverting amplifier given by Eq. (4) can be approximated by

$$\frac{y}{x} \simeq \frac{-A}{bA} = -\frac{1}{b} \quad (6)$$

These are important results, for they show that the gain is set by the feedback network and not by the amplifier. In practice, this means that an amplifier without feedback can be designed without too much consideration of what its gain will be as long as the gain is high enough. When feedback is added, the gain can be reduced to any desired value by the feedback network.

The product bA in Eqs. (2) and (4) must be dimensionless. Thus if A is a voltage gain (voltage in-voltage out) or a current gain (current in-current out), then b must be dimensionless. If A is a transconductance gain (voltage in-current out), b must have the units of ohms (Ω). If A is a transresistance gain (current in-voltage out), b must have the units siemens (\mathcal{U}). How these are determined is illustrated below.

We have assumed so far that the gains A and b are positive real constants. In general, the gains are phasor functions of frequency. This leads to a stability problem in feedback amplifiers. As frequency is increased, $|A|$ must eventually decrease because no amplifier can have an infinite bandwidth. The decrease in $|A|$ is accompanied with a phase shift so that bA can be equal to a negative real number at some frequency. Suppose that $bA = -1$ at some frequency. Eqs. (3) and (4) show that the gain becomes infinite at that frequency. An amplifier with an infinite gain at any frequency can put out a signal at that frequency with no input signal. In this case, the amplifier is said to oscillate. It can be shown that an amplifier will oscillate if $|bA| \geq 1$ at any frequency for which bA is a negative real number, i.e. the phase of bA is $\pm 180^\circ$.

In the block diagrams of Fig. 1, the input and output variables can be modeled as either a voltage or a current. It follows that there are four combinations of inputs and outputs that represent the possible types of feedback. These are summarized in Table 1 where the names for each are given. These names come from the way that the feedback network connects between the input and output stages. This is explained in the following for each type of feedback.

Table 1. The Four Types of Feedback

Name	Input Variable x	Output Variable y	Error Variable z	Forward Gain A	Feedback Factor b
Series-Shunt	Voltage v	Voltage v	Voltage v	Voltage Gain	Dimensionless
Shunt-Shunt	Current i	Voltage v	Current i	Transresistance	siemens (\mathcal{U})
Series-Series	Voltage v	Current i	Voltage v	Transconductance	ohms (Ω)
Shunt-Series	Current i	Current i	Current i	Current Gain	Dimensionless

The Mason Signal-Flow Graph

The analysis of feedback amplifiers is facilitated by the use of the Mason signal-flow graph. A signal-flow graph is a graphical representation of a set of linear equations which can be used to

write by inspection the solution to the set of equations. For example, consider the set of equations

$$x_2 = Ax_1 + Bx_2 + Cx_5 \quad (7)$$

$$x_3 = Dx_1 + Ex_2 \quad (8)$$

$$x_4 = Fx_3 + Gx_5 \quad (9)$$

$$x_5 = Hx_4 \quad (10)$$

$$x_6 = Ix_3 \quad (11)$$

where x_1 through x_6 are variables and A through I are constants. These equations can be represented graphically as shown in Fig. 2. The graph has a node for each variable with branches connecting the nodes labeled with the constants A through I . The node labeled x_1 is called a source node because it has only outgoing branches. The node labeled x_6 is called a sink node because it has only incoming branches. The path from x_1 to x_2 to x_3 to x_6 is called a forward path because it originates at a source node and terminates at a non-source node and along which no node is encountered twice. The path gain for this forward path is AEI . The path from x_2 to x_3 to x_4 to x_5 is called a feedback path because it originates and terminates on the same node and along which no node is encountered more than once. The loop gain for this feedback path is $EFHC$.

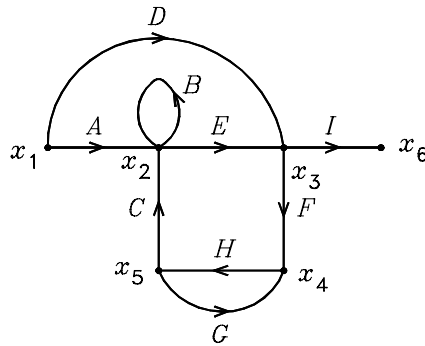

Figure 2: Flow graph for the equations.

Mason's formula can be used to calculate the transmission gain from a source node to any non-source node in a flow graph. The formula is

$$T = \frac{1}{\Delta} \sum_k P_k \Delta_k \quad (12)$$

where P_k is the gain of the k th forward path, Δ is the graph determinant, and Δ_k is the determinant with the k th forward path erased. The determinant is given by

$$\begin{aligned} \Delta = & 1 - (\text{sum of all loop gains}) \\ & + \left(\text{sum of the gain products of all possible} \right. \\ & \quad \left. \text{combinations of two non-touching loops} \right) \\ & - \left(\text{sum of the gain products of all possible} \right. \\ & \quad \left. \text{combinations of three non-touching loops} \right) \\ & + \left(\text{sum of the gain products of all possible} \right. \\ & \quad \left. \text{combinations of four non-touching loops} \right) \\ & - \dots \end{aligned} \quad (13)$$

For the flow graph in Fig. 2, the objective is to solve for the gain from node x_1 to node x_6 . There are two forward paths from x_1 to x_6 and three loops. Two of the loops do not touch each other. Thus the product of these two loop gains appears in the expression for Δ . The path gains and the determinant are given by

$$P_1 = AEI \quad (14)$$

$$P_2 = DI \quad (15)$$

$$\Delta = 1 - (B + CEFH + GH) + B \times GH \quad (16)$$

Path P_1 touches two loops while path P_2 touches one loop. The determinants with each path erased are given by

$$\Delta_1 = 1 - GH \quad (17)$$

$$\Delta_2 = 1 - (B + GH) + B \times GH \quad (18)$$

Thus the overall gain from x_1 to x_6 is given by

$$\frac{x_6}{x_1} = \frac{AEI \times (1 - GH) + DI \times [1 - (B + GH) + B \times GH]}{1 - (B + CEFH + GH) + B \times GH} \quad (19)$$

This equation can also be obtained by algebraic solution of the equations in Eqs. (7) through (11).

Review of Background Theory

This section summarizes several BJT small-signal ac equivalent circuits which are used to write the circuit equations in the following sections. Fig. 3(a) shows an npn BJT with Thévenin sources connected to its base and emitter and a load resistor connected to its collector. First we define the emitter intrinsic resistance r_e , the collector-emitter resistance r_0 , the resistance r'_e , and the transconductance G_m . These are given by

$$r_e = \frac{V_T}{I_E} \quad (20)$$

$$r_0 = \frac{V_{CE} + V_A}{I_C} \quad (21)$$

$$r'_e = \frac{R_{tb} + r_x}{1 + \beta} + r_e \quad (22)$$

$$G_m = \frac{a}{r'_e + R_{te}} \quad (23)$$

where V_T is the thermal voltage, I_E is the emitter bias current, V_{CE} is the quiescent collector-emitter voltage, V_A is the Early voltage, I_C is the quiescent collector current, r_x is the base spreading resistance, β is the base-collector current gain, and α is the emitter-collector current gain. The latter two are related by $\alpha = \beta / (1 + \beta)$ and $\beta = \alpha / (1 - \alpha)$.

The small-signal ac Thévenin equivalent circuit seen looking into the base is shown in Fig. 3(b), where $v_{b(oc)}$ and r_{ib} are given by

$$v_{b(oc)} = v_{te} \frac{r_0 + R_{tc}}{R_{te} + r_0 + R_{tc}} \quad (24)$$

$$r_{ib} = r_x + (1 + \beta) r_e + R_{te} \frac{(1 + \beta) r_0 + R_{tc}}{r_0 + R_{te} + R_{tc}} \quad (25)$$

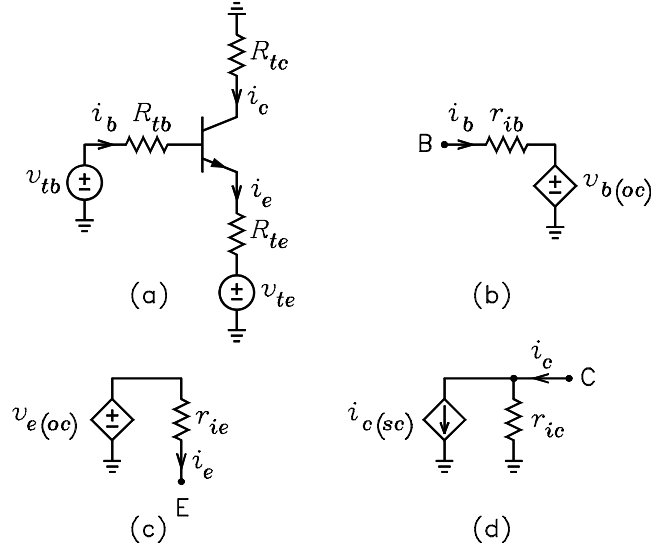

Figure 3: Small-signal equivalent circuits.

The small-signal ac Thévenin equivalent circuit seen looking into the emitter is shown in Fig. 3(c), where $v_{e(oc)}$ and r_{ie} are given by

$$v_{e(oc)} = v_{tb} \frac{r_0 + R_{tc}/(1 + \beta)}{r'_e + r_0 + R_{tc}/(1 + \beta)} \quad (26)$$

$$r_{ie} = r'_e \frac{r_0 + R_{tc}}{r_{ie} + r_0 + R_{tc}/(1 + \beta)} \quad (27)$$

The small-signal ac Norton equivalent circuit seen looking into the collector is shown in Fig. 3(d), where $i_{c(sc)}$ and r_{ic} are given by

$$i_{c(sc)} = G_{mb}v_{tb} - G_{me}v_{te} \quad (28)$$

$$r_{ic} = \frac{r_0 + r'_e \parallel R_{te}}{1 - G_m R_{te}} \quad (29)$$

The transconductances G_{mb} and G_{me} are given by

$$G_{mb} = G_m \frac{r_0 - R_{te}/\beta}{r_0 + r'_e \parallel R_{te}} \quad (30)$$

$$G_{me} = G_m \frac{r_0 + r'_e/\alpha}{r_0 + r'_e \parallel R_{te}} \quad (31)$$

The r_0 Approximations

In some of the examples that follow, the analysis is simplified by making use of the so-called r_0 approximations. That is, we assume that $r_0 \rightarrow \infty$ in all equations except in the one for r_{ic} . This assumption makes G_{mb} , G_{me} , r_{ib} , and r_{ie} independent of r_0 . In addition, it makes $G_{mb} = G_{me}$ so that we can denote $G_{mb} = G_{me} = G_m$. In this case,

$$i_{c(sc)} = G_m (v_{tb} - v_{te}) = \frac{\alpha}{r'_e + R_{te}} (v_{tb} - v_{te}) \quad (32)$$

$$v_{b(oc)} = v_{te} \quad (33)$$

$$r_{ib} = r_x + (1 + \beta)(r_e + R_{te}) \quad (34)$$

$$v_{e(oc)} = v_{tb} \quad (35)$$

$$r_{ie} = r'_e \quad (36)$$

$$i_b = \frac{i_{c(sc)}}{\beta} \quad (37)$$

$$i_e = \frac{i_{c(sc)}}{\alpha} \quad (38)$$

If $v_{te} = 0$ and $R_{re} = 0$, r_0 appears as a resistor from the collector to ground. If $R_{tc} = 0$, r_0 appears as a resistor from emitter to ground. In either case, r_0 can be easily included in the analysis by treating it as an external resistor from either the emitter or the collector to ground.

Series-Shunt Feedback

A series-shunt feedback amplifier is a non-inverting amplifier in which the input signal x is a voltage and the output signal y is a voltage. If the input source is a current source, it must be converted into a Thévenin source for the gain to be in the form of Eq. (2). Because the input is a voltage and the output is a voltage, the gain A represents a dimensionless voltage gain. Because bA must be dimensionless, the feedback factor is also dimensionless. Two examples are given below. The first is an op-amp example. The second is a BJT example.

Op Amp Example

Fig. 4(a) shows an op amp with a feedback network consisting of a voltage divider connected between its output and inverting input. The input signal is connected to the non-inverting input. Because the feedback does not connect to the same terminal as the input signal, the summing is series. The feedback network connects in shunt with the output node, thus the sampling is shunt.

To analyze the circuit, we replace the circuit seen looking out of the op-amp inverting input with a Thévenin equivalent circuit with respect to v_o and the circuit seen looking into the feedback network from the v_o node with a Thévenin equivalent circuit with respect to i_1 . We replace the op amp with a simple controlled source model which models the differential input resistance, the open-loop voltage gain, and the output resistance. A test source i_t is added at the output in order to calculate the output resistance. The circuit is shown in Fig. 4(b), where R_{id} is the differential input resistance, A_0 is the open-loop gain, R_0 is the output resistance of the op amp. The feedback factor b is given by

$$b = \frac{R_1}{R_1 + R_F} \quad (39)$$

The error signal z in Fig. 4(b) is a voltage which we denote by v_e . It is the difference between the two voltage sources in the input circuit and is given by

$$v_e = v_s - bv_o \quad (40)$$

By voltage division, the voltage v_i which controls the op amp output voltage is

$$v_i = v_e \frac{R_{id}}{R_S + R_{id} + R_1 \parallel R_F} \quad (41)$$

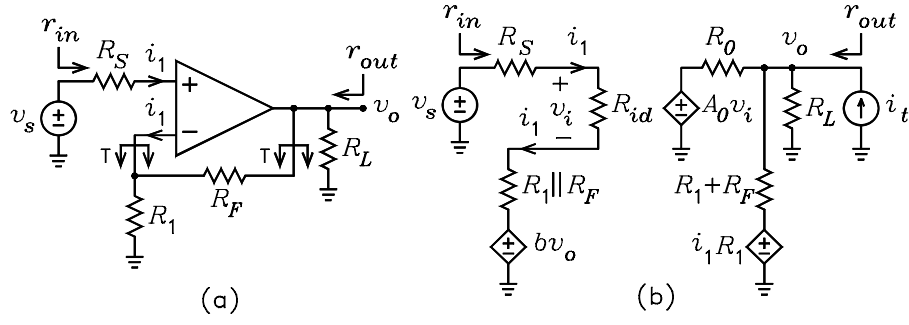

Figure 4: (a) Series-shunt op-amp example. (b) Circuit with feedback removed.

Signal tracing shows that the negative feedback has the effect of making the current i_1 smaller. For this reason, we will neglect the $i_1 R_1$ source in the output circuit in calculating v_o . By superposition, it follows that v_o can be written

$$v_o = A_0 v_i \frac{(R_1 + R_F) \parallel R_L}{R_0 + (R_1 + R_F) \parallel R_L} + i_t R_0 \parallel (R_1 + R_F) \parallel R_L \quad (42)$$

To calculate the input resistance, we need the current i_1 . It is given by

$$i_1 = \frac{v_i}{R_{id}} \quad (43)$$

To simplify the equations, let us define

$$k_1 = \frac{R_{id}}{R_S + R_{id} + R_1 \parallel R_F} \quad (44)$$

$$k_2 = \frac{(R_1 + R_F) \parallel R_L}{R_0 + (R_1 + R_F) \parallel R_L} \quad (45)$$

$$R_{eq} = R_0 \parallel (R_1 + R_F) \parallel R_L \quad (46)$$

The circuit equations can be rewritten

$$v_i = k_1 v_e \quad (47)$$

$$v_o = k_2 A_0 v_i + i_t R_{eq} \quad (48)$$

The flow graph for these equations is shown in Fig. 5. The determinant is given by

$$\Delta = 1 - [k_1 k_2 A_0 (-b)] = 1 + b k_1 k_2 A_0 = 1 + bA \quad (49)$$

From the flow graph, the voltage gain is given by

$$\frac{v_o}{v_s} = \frac{1}{\Delta} k_1 k_2 A_0 = \frac{k_1 k_2 A_0}{1 + b k_1 k_2 A_0} = \frac{A}{1 + bA} \quad (50)$$

It follows that A is given by

$$A = k_1 k_2 A_0 \quad (51)$$

This is the gain from v_s to v_o with $b = 0$. If $bA \gg 1$, the gain approaches

$$\frac{v_o}{v_s} \rightarrow \frac{A}{bA} = \frac{1}{b} = 1 + \frac{R_F}{R_1} \quad (52)$$

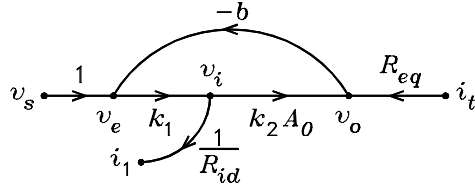

Figure 5: Flow graph for the series-shunt op-amp example.

This is the familiar formula for the gain of the non-inverting op amp.

From the flow graph, the output resistance is given by

$$r_{out} = \frac{v_o}{i_t} = \frac{1}{\Delta} R_{eq} = \frac{R_{0} \parallel (R_1 + R_F) \parallel R_L}{1 + bA} \quad (53)$$

Similarly, the input resistance is given by

$$r_{in} = \left(\frac{i_1}{v_s} \right)^{-1} = \left(\frac{1}{\Delta} \frac{k_1}{R_{id}} \right)^{-1} = (1 + bA) (R_S + R_{id} + R_1 \parallel R_F) \quad (54)$$

Note that the voltage gain and the output resistance are decreased by the feedback. The input resistance is increased by the feedback. These are properties of the series-shunt topology.

Transistor Example

The ac signal circuit of an example BJT series-shunt feedback amplifier is shown in Fig. 6. We assume that the dc solutions to the circuit are known. The feedback network is in the form of a voltage divider and consists of resistors R_{F1} and R_{F2} . Because the input to the feedback network connects to the v_o node, the amplifier is said to employ shunt sampling at the output. The output of the feedback network connects to the emitter of Q_1 . Because this is not the node to which v_s connects, the circuit is said to have series summing at the input. The following analysis assumes the r_0 approximations for Q_1 . That is, we neglect r_0 in all equations except when calculating r_{ic1} .

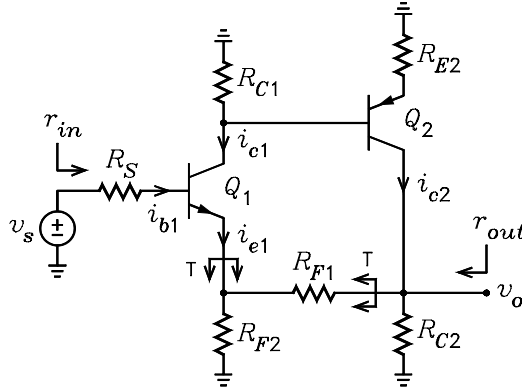

Figure 6: Series-shunt amplifier.

In order for the amplifier to have negative feedback, the voltage gain from the emitter of Q_1 to the collector of Q_2 must be inverting. When the feedback signal is applied to its emitter, Q_1 is a

common-base stage which has a non-inverting voltage gain. Q_2 is a common-emitter stage which has an inverting gain. Thus the amplifier has an inverting voltage gain from the emitter of Q_1 to the collector of Q_2 so that the feedback is negative.

To remove the feedback, we replace the circuit seen looking out of the emitter of Q_1 with a Thévenin equivalent circuit with respect to v_o . The circuit seen looking into R_{F1} from the v_o node is replaced with a Thévenin equivalent circuit with respect to i_{e1} . Fig. 7 shows the circuit. A test current source is connected to the v_o node to calculate r_{out} . The Thévenin voltage looking out of the emitter of Q_1 is given by

$$v_{te1} = v_o \frac{R_1}{R_1 + R_F} = bv_o \quad (55)$$

where b is the feedback factor given by

$$b = \frac{R_1}{R_1 + R_F} \quad (56)$$

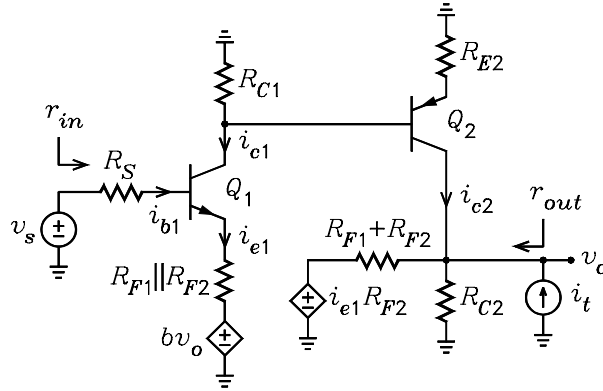

Figure 7: Circuit with feedback removed.

For the circuit of Fig. 7, the error voltage v_e is given by

$$v_e = v_s - bv_o \quad (57)$$

Signal tracing shows that the negative feedback has the effect of making the current i_{e1} smaller. For this reason, we will neglect it in calculating v_o . To circuit equations are

$$i_{c1(sc)} = G_{m1} (v_s - bv_o) = G_{m1} v_e \quad (58)$$

$$v_{tb2} = -i_{c1(sc)} r_{ic1} \parallel R_{C1} \quad (59)$$

$$R_{tb2} = r_{ic1} \parallel R_{C1} \quad (60)$$

$$i_{c2(sc)} = -G_{mb2} v_{tb2} \quad (61)$$

$$v_o = [i_{c2(sc)} + i_t] \times r_{ic2} \parallel R_{C2} \parallel (R_{F1} + R_{F2}) \quad (62)$$

To solve for r_{in} , we need i_{b1} . If we use the r_0 approximations, it is given by

$$i_{b1} = \frac{i_{c1(sc)}}{\beta_1} \quad (63)$$

To simplify the flow graph, let us define

$$R_{eq1} = r_{ic1} \parallel R_{C1} \quad (64)$$

$$R_{eq2} = r_{ic2} \parallel R_{C2} \parallel (R_{F1} + R_{F2}) \quad (65)$$

The flow graph for the equations is shown in Fig. 8. The determinant is given by

$$\Delta = 1 - [G_{m1}(-R_{eq1})(-G_{m2})R_{eq2}(-b)] = 1 + bA \quad (66)$$

where A is given by

$$A = G_{m1}R_{eq1}G_{m2}R_{eq2} \quad (67)$$

This is the gain from v_s to v_o with $b = 0$. From the flow graph, the voltage gain is given by

$$\frac{v_o}{v_s} = \frac{1}{\Delta} G_{m1}R_{eq1}G_{m2}R_{eq2} = \frac{A}{1 + bA} \quad (68)$$

The output resistance is given by

$$r_{out} = \frac{v_o}{i_t} = \frac{1}{\Delta} R_{eq2} = \frac{R_{eq2}}{1 + bA} \quad (69)$$

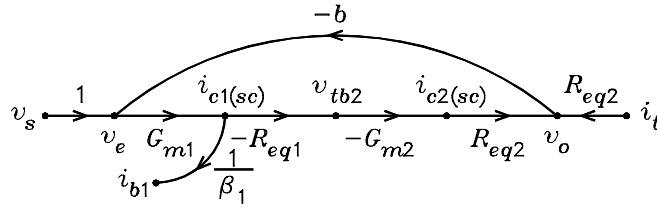

Figure 8: Flow graph for the series-shunt example.

The input resistance is given by $r_{in} = v_s/i_{b1}$. Because v_s is an independent variable, it can be used to solve for i_{b1}/v_s not v_s/i_{b1} . Thus the input resistance can be written

$$r_{in} = \left(\frac{i_{b1}}{v_s}\right)^{-1} = \left(\frac{1}{\Delta} \frac{G_{m1}}{\beta_1}\right)^{-1} = \Delta \frac{\beta_1}{G_{m1}} \quad (70)$$

But β_1/G_{m1} is given by

$$\frac{\beta_1}{G_{m1}} = \beta_1 \frac{r'_{e1} + R_{te1}}{\alpha_1} = R_S + r_{x1} + (1 + \beta_1)(r_{e1} + R_{te1}) \quad (71)$$

Thus r_{in} is given by

$$r_{in} = (1 + bA) [R_S + r_{x1} + (1 + \beta_1)(r_{e1} + R_{te1})] \quad (72)$$

Summary of the Effects of Series-Shunt Feedback

From the examples above, it can be seen that the voltage gain is divided by the factor $(1 + bA)$. The input resistance is multiplied by the factor $(1 + bA)$. And the output resistance is divided by the factor $(1 + bA)$.

Shunt-Shunt Feedback

A shunt-shunt feedback amplifier is an inverting amplifier in which the input signal x is a current and the output signal y is a voltage. If the input source is a voltage source, it must be converted into a Norton source for the gain to be in the form of Eq. (4). Because the input is a current and the output is a voltage, the gain A represents a transresistance with the units Ω . Because bA must be dimensionless, the feedback factor has the units of V . Two examples are given below. The first is an op-amp example. The second is a BJT example.

Op Amp Example

Fig. 9(a) shows an op amp with a feedback network consisting of a resistor connected between its output and its inverting input. The input signal is connected through a resistor to the inverting input. Because the feedback connects to the same terminal as the input signal, the summing is shunt. The feedback network connects in shunt with the output node, thus the sampling is shunt.

To analyze the circuit, we replace the circuit seen looking out of the v_i node through R_S with a Norton equivalent circuit with respect to v_s and the circuit seen looking out of the v_i node through R_F with a Norton equivalent circuit with respect to v_o . This must always be done with the shunt-shunt amplifier in order for the gain with feedback to be of the form $-A/(1+bA)$, where A and b are positive and the $-$ sign is necessary because the circuit has an inverting gain. In addition, we replace the circuit seen looking out of the v_o node through R_F with a Thévenin equivalent circuit with respect to v_i .

The circuit with feedback removed is shown in Fig. 9(b), where r'_{in} is the input resistance seen by the source current i_s . The Norton current seen looking out of the v_i node is represented by the bv_o source, where b is the feedback factor. The current i_s and the feedback factor are given by

$$i_s = \frac{v_s}{R_S} \quad (73)$$

$$b = \frac{1}{R_F} \quad (74)$$

The error current i_e is the total current delivered to the v_i node. It is given by

$$i_e = i_s + bv_o \quad (75)$$

Because v_o is negative when i_s is positive, the current bv_o subtracts from i_s to cause i_e to be decreased.

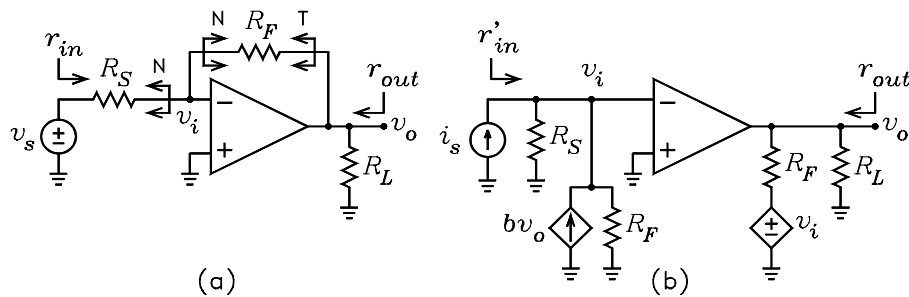

Figure 9: (a) Shunt-shunt op amp circuit. (b) Circuit with feedback removed.

Fig. 10 shows the circuit with the op amp replaced with a controlled source model which models the differential input resistance R_{id} , the open-loop voltage gain A_0 , and the output resistance R_0 .

A test source i_t is added at the output in order to calculate the output resistance. The voltage v_i controls the op-amp output voltage. It is given by

$$v_i = (i_s + bv_o) R_S \parallel R_F \parallel R_{id} = i_e R_S \parallel R_F \parallel R_{id} \quad (76)$$

Signal tracing shows that the negative feedback has the effect of making the voltage v_i smaller. For this reason, we will neglect the v_i source in calculating v_o . It follows that v_o is given by

$$v_o = -A_0 v_i \frac{R_F \parallel R_L}{R_0 + R_F \parallel R_L} + i_t R_0 \parallel R_F \parallel R_L \quad (77)$$

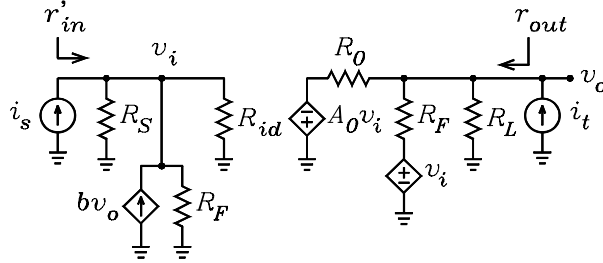

Figure 10: Shunt-shunt circuit with the op amp replaced with a controlled source model.

To simplify the equations, let us define

$$R_{eq1} = R_S \parallel R_F \parallel R_{id} \quad (78)$$

$$R_{eq2} = R_0 \parallel R_F \parallel R_L \quad (79)$$

$$k = \frac{R_F \parallel R_L}{R_0 + R_F \parallel R_L} \quad (80)$$

The circuit equations can be rewritten

$$i_e = i_s + bv_o \quad (81)$$

$$v_i = i_e R_{eq1} \quad (82)$$

$$v_o = -k A_0 v_i + i_t R_{eq2} \quad (83)$$

The flow graph for these equations is shown in Fig. 11. The determinant is given by

$$\Delta = 1 - [R_{eq1} (-A_0 k) b] = 1 + b R_{eq1} A_0 k \quad (84)$$

From the flow graph, the transresistance gain is given by

$$\frac{v_o}{i_s} = \frac{1}{\Delta} (-R_{eq1} A_0 k) = \frac{-R_{eq1} A_0 k}{1 + b R_{eq1} A_0 k} = \frac{-A}{1 + bA} \quad (85)$$

It follows that A is given by

$$A = R_{eq1} A_0 k \quad (86)$$

If $bA \gg 1$, the transresistance gain approaches

$$\frac{v_o}{i_s} \rightarrow \frac{-A}{bA} = -\frac{1}{b} = -R_F \quad (87)$$

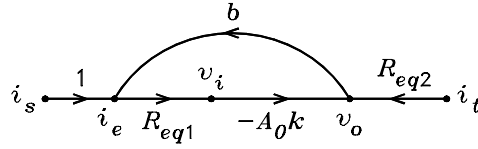

Figure 11: Flow graph for the shunt-shunt amplifier.

We note that A is the negative of the gain from i_s to v_o calculated with $b = 0$. Also, $-bA$ is the loop gain in the flow graph.

From the flow graph, the output resistance is given by

$$r_{out} = \frac{v_o}{i_t} = \frac{1}{\Delta} R_{eq2} = \frac{R_O \| R_F \| R_L}{1 + bA} \quad (88)$$

Similarly, the input resistance is given by

$$r'_{in} = \frac{v_i}{i_s} = \frac{1}{\Delta} R_{eq1} = \frac{R_S \| R_F \| R_{id}}{1 + bA} \quad (89)$$

We note that R_{eq2} is the output resistance with the v_i source zeroed at the output. Also, R_{eq1} is the input resistance with the bv_o source zeroed at the input.

The voltage gain of the original circuit in Fig. 9(a) is given by

$$\frac{v_o}{v_s} = \frac{i_s}{v_s} \frac{v_o}{i_s} = \frac{1}{R_S} \frac{-A}{1 + bA} \simeq \frac{1}{R_S} \frac{-A}{bA} = -\frac{R_F}{R_S} \quad (90)$$

where the approximation holds for $bA \gg 1$. This is the familiar gain expression for the inverting op amp amplifier. The input resistance is obtained from r'_{in} with the relation

$$r_{in} = R_S + \left(\frac{1}{r'_{in}} - \frac{1}{R_S} \right)^{-1} \quad (91)$$

Transistor Example

Fig. 12 shows the ac signal circuit of an example BJT shunt-shunt feedback amplifier. The feedback network consists of the resistor R_F which connects between the output and input nodes. Because R_F connects to the output node, the amplifier is said to have shunt sampling. Because the current fed back through R_F to the input node combines in parallel with the source current, the circuit is said to have shunt summing. Thus the amplifier is said to have shunt-shunt feedback. In order for the feedback to be negative, the voltage gain from v_i to v_o must be inverting. Q_1 is a common-emitter stage which has an inverting gain. Q_2 is a common-collector stage which has a non-inverting gain. Thus the overall voltage gain is inverting so that the feedback is negative.

Fig. 13 shows the equivalent circuit with feedback removed. The circuits seen looking out of the v_i node through R_S and through R_F , respectively, are converted into Norton equivalent circuits with respect to v_s and v_o . The source current i_s and the feedback factor b are given by

$$i_s = \frac{v_s}{R_S} \quad (92)$$

$$b = \frac{1}{R_F} \quad (93)$$

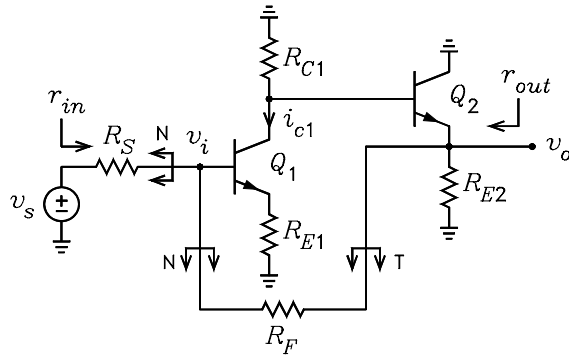

Figure 12: Example BJT shunt-shunt amplifier.

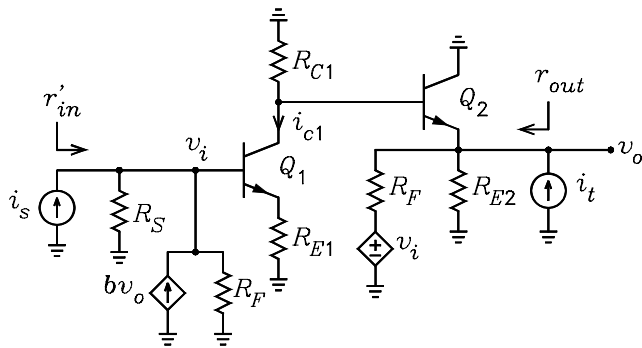

Figure 13: Shunt-shunt amplifier with feedback removed.

The feedback network at the output is modeled by a Thévenin equivalent circuit with respect to v_i . The external current source i_t is added to the circuit so that the output resistance can be calculated. Signal tracing shows that the input voltage v_i is reduced by the feedback. Therefore, we neglect the effect of the v_i controlled source in the output circuit when calculating v_o .

The circuit equations are

$$v_{tb1} = i_e R_S \parallel R_F = i_e R_{eq1} \quad (94)$$

$$i_e = i_s + b v_o \quad (95)$$

$$v_i = i_e R_S \parallel R_F \parallel r_{ib1} = i_e R_{eq2} \quad (96)$$

$$i_{c1(sc)} = G_{mb1} v_{tb1} \quad (97)$$

$$v_{tb2} = -i_{c1(sc)} r_{ic1} \parallel R_{C1} = -i_{c1(sc)} R_{eq3} \quad (98)$$

$$v_{e2(oc)} = \frac{r_{o2}}{r'_{e2} + r_{o2}} v_{tb2} = k_1 v_{tb2} \quad (99)$$

$$v_o = \frac{R_{E2} \parallel R_F}{r_{ie2} + R_{E2} \parallel R_F} v_{e2(oc)} + i_t \times r_{ie2} \parallel R_{E2} \parallel R_F = k_2 v_{e2(oc)} + i_t R_{eq4} \quad (100)$$

The flow graph for the equations is shown in Fig. 14. The determinant is given by

$$\Delta = 1 - [R_{eq1} G_{mb1} (-R_{eq3}) k_1 k_2 b] = 1 + b R_{eq1} G_{mb1} R_{eq3} k_1 k_2 \quad (101)$$

The transresistance gain is given by

$$\frac{v_o}{i_s} = \frac{1}{\Delta} R_{eq1} G_{mb1} (-R_{eq3}) k_1 k_2 = \frac{-R_{eq1} G_{mb1} R_{eq3} k_1 k_2}{1 + b R_{eq1} G_{mb1} R_{eq3} k_1 k_2} = \frac{-A}{1 + bA} \quad (102)$$

It follows that A is given by

$$A = R_{eq1} G_{mb1} R_{eq3} k_1 k_2 \quad (103)$$

The input and output resistances are given by

$$r'_{in} = \frac{v_i}{i_s} = \frac{R_{eq2}}{\Delta} = \frac{R_1 \parallel R_F \parallel r_{ib1}}{\Delta} \quad (104)$$

$$r_{out} = \frac{v_o}{i_t} = \frac{R_{eq4}}{\Delta} = \frac{r_{ie2} \parallel R_{E2} \parallel R_F}{\Delta} \quad (105)$$

It can be seen from these expressions that the transresistance gain, the input resistance, and the output resistance are all decreased by a factor equal to the amount of feedback.

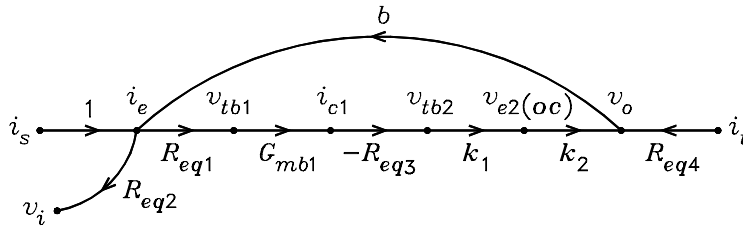

Figure 14: Flow graph for the shunt-shunt amplifier.

The voltage gain of the original circuit in Fig. 12 is given by

$$\frac{v_o}{v_s} = \frac{i_s}{v_s} \frac{v_o}{i_s} = \frac{1}{R_S} \frac{-A}{1 + bA} \simeq \frac{1}{R_S} \frac{-A}{bA} = -\frac{R_F}{R_S} \quad (106)$$

where the approximation holds for $bA \gg 1$. This is the familiar gain expression for the inverting op amp amplifier. The input resistance is obtained from r'_{in} with the relation

$$r_{in} = R_S + \left(\frac{1}{r'_{in}} - \frac{1}{R_S} \right)^{-1} \quad (107)$$

Summary of the Effects of Shunt-Shunt Feedback

Notice from the examples above that the transresistance gain and the voltage gain are divided by the factor $(1 + bA)$. The input resistance r'_{in} is divided by the factor $(1 + bA)$. And the output resistance is divided by the factor $(1 + bA)$.

Series-Series Feedback

A series-series feedback amplifier is a non-inverting amplifier in which the input signal x is a voltage and the output signal y is a current. If the input source is a current source, it must be converted into a Thévenin source for the gain to be in the form of Eq. (2). Because the input is a voltage and the output is a current, the gain A represents a transconductance with the units \bar{O} . Because bA must be dimensionless, the feedback factor has the units of Ω . An op-amp example is given below.

Fig. 15(a) shows an op-amp circuit in which a resistor R_1 is in series with the load resistor R_L . The voltage across R_1 is fed back into the inverting op-amp input. The voltage across R_1 is proportional to the output current i_o . This is said to be series sampling at the output. Because the feedback does not connect to the same op-amp input as the source, the circuit is said to have series summing. Thus the circuit is called a series-series feedback amplifier.

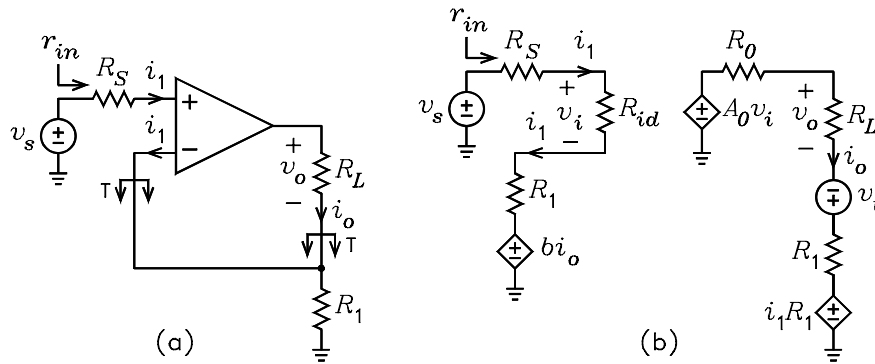

Figure 15: (a) Example series-series feedback amplifier. (b) Circuit with feedback removed.

To remove the feedback, the circuit seen looking out of the op-amp inverting input is replaced with a Thévenin equivalent circuit with respect to i_o . The circuit seen looking below R_L is replaced with a Thévenin equivalent circuit with respect to i_1 . The circuit with feedback removed is shown in Fig. 15(b), where the op amp is replaced with a controlled source model that models its differential input resistance R_{id} , its gain A_0 , and its output resistance R_0 . The feedback factor b is given by

$$b = R_1$$

A test voltage source v_t is added in series with R_L to calculate the output resistance. We define the resistance r_{out} as the effective series resistance in the output circuit, including R_L . It is given by $r_{out} = v_t/i_o$. The output resistance seen by R_L is given by $r'_{out} = r_{out} - R_L$. Because R_L is floating, it is not possible to label r_{out} on the diagram.

Signal tracing shows that the negative feedback has the effect of reducing i_1 . For this reason, the $i_1 R_1$ source in the output circuit will be neglected in solving for i_o . We can write the following equations

$$v_e = v_s - bi_o \quad (108)$$

$$v_i = \frac{R_{id}}{R_S + R_{id} + R_1} v_e \quad (109)$$

$$i_o = \frac{A_0 v_i}{R_0 + R_L + R_1} + \frac{v_t}{R_0 + R_L + R_1} \quad (110)$$

$$i_1 = \frac{v_i}{R_{id}} \quad (111)$$

To simplify the equations, let us define

$$k = \frac{R_{id}}{R_S + R_{id} + R_1} \quad (112)$$

$$R_{eq} = R_0 + R_L + R_1 \quad (113)$$

The circuit equations can be rewritten

$$v_i = k v_e \quad (114)$$

$$i_o = \frac{A_0 v_i}{R_{eq}} + \frac{v_t}{R_{eq}} \quad (115)$$

The flow graph for these equations is shown in Fig. 16. The determinant is given by

$$\Delta = 1 - \left[k \frac{A_0}{R_{eq}} (-b) \right] = 1 + bk \frac{A_0}{R_{eq}} = 1 + bA \quad (116)$$

From the flow graph, the transconductance gain is given by

$$\frac{i_o}{v_s} = \frac{1}{\Delta} k \frac{A_0}{R_{eq}} = \frac{k A_0 / R_{eq}}{1 + bk A_0 / R_{eq}} = \frac{A}{1 + bA} \quad (117)$$

It follows that A is given by

$$A = k \frac{A_0}{R_{eq}} \quad (118)$$

This is the gain from v_s to i_o with $b = 0$. If $bA \gg 1$, the gain approaches

$$\frac{i_o}{v_s} \rightarrow \frac{A}{bA} = \frac{1}{b} = \frac{1}{R_1} \quad (119)$$

This is the gain obtained by assuming the op amp is ideal. Because it has negative feedback, there is a virtual short between its two inputs so that the voltage at the upper node of R_1 is v_s and the current through R_1 is v_s/R_1 . Thus the output current is $i_o = v_s/R_1$.

The input resistance r_{in} and the output resistance r_{out} are given by

$$r_{in} = \left(\frac{i_1}{v_s} \right)^{-1} = \left(\frac{1}{\Delta} \frac{k}{R_{id}} \right)^{-1} = \Delta \frac{R_{id}}{k} = (1 + bA) (R_S + R_{id} + R_1) \quad (120)$$

$$r_{out} = \left(\frac{i_o}{v_t} \right)^{-1} = \left(\frac{1}{\Delta} \frac{1}{R_{eq}} \right)^{-1} = (1 + bA) (R_0 + R_L + R_1) \quad (121)$$

Note that the effect of the the feedback is to reduce the gain, increase the input resistance and increase the output resistance. In the case $bA \rightarrow \infty$, the output resistance becomes infinite and the load resistor R_L is driven by an ideal current source.

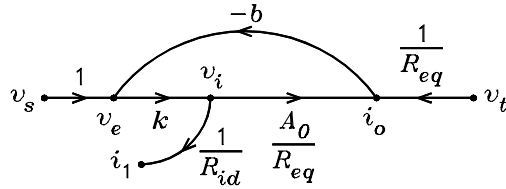

Figure 16: Flow graph for the series-series feedback amplifier.

Shunt-Series Feedback

A shunt-series feedback amplifier is an inverting amplifier in which the input signal x is a voltage and the output signal y is a current. If the input source is a voltage source, it must be converted into a Norton source for the gain to be in the form of Eq. (4). Because the input is a current and the output is a current, the gain A represents a dimensionless current gain. Because bA must be dimensionless, the feedback factor is dimensionless. An op-amp example is given below.

Fig. 17(a) shows an op-amp circuit in which a resistor R_1 connects from the lower node of the load resistor R_L to ground. The voltage across R_1 causes a current to flow through the feedback resistor R_F into the inverting op-amp input. The current through R_F is proportional to the output current i_o . This is said to be series sampling at the output. Because the feedback connects to the same op-amp input as the source, the circuit is said to have shunt summing at the input. Thus the circuit is called a shunt-series feedback amplifier.

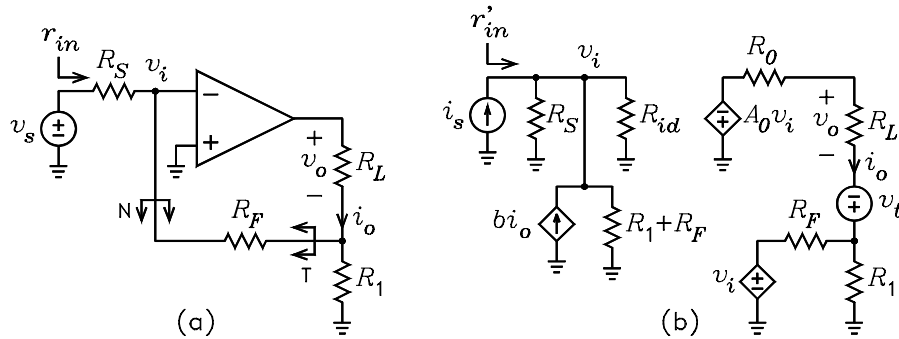

Figure 17: (a) Shunt-series amplifier example. (b) Circuit with feedback removed.

To analyze the circuit, we replace the circuit seen looking out of the v_i node through R_S with a Norton equivalent circuit with respect to v_s and the circuit seen looking out of the v_i node through R_F with a Norton equivalent circuit with respect to i_o . This must always be done with the shunt-series amplifier in order for the gain with feedback to be of the form $-A/(1+bA)$, where A and b are positive and the $-$ sign is necessary because the circuit has an inverting gain. In addition, we replace the circuit seen looking through R_F into the v_i node with a Thévenin equivalent circuit with respect to v_i . The circuit with feedback removed is shown in Fig. 17(b), where the op amp is replaced with a controlled source model that models its differential input resistance R_{id} , its gain A_0 , and its output resistance R_0 . The feedback factor b is a current divider ratio given by

$$b = \frac{R_1}{R_1 + R_F} \quad (122)$$

A test voltage source v_t is added in series with R_L to calculate the output resistance. We define the resistance r_{out} as the effective series resistance in the output circuit, including R_L . It is given by $r_{out} = v_t/i_o$. The output resistance seen by R_L is given by $r'_{out} = r_{out} - R_L$. Because R_L is floating, it is not possible to label r_{out} on the diagram.

Signal tracing shows that the negative feedback has the effect of reducing v_i . For this reason, the v_i source in the output circuit will be neglected in solving for i_o . The error current i_e is the sum of the two current sources in the input circuit. We can write the following equations

$$i_e = i_s + bi_o \quad (123)$$

$$v_i = i_e R_S \parallel (R_1 + R_F) \parallel R_{id} = i_e R_{eq1} \quad (124)$$

$$i_o = \frac{-A_0 v_i}{R_0 + R_L + R_1 \parallel R_F} + \frac{v_t}{R_0 + R_L + R_1 \parallel R_F} = \frac{-A_0 v_i}{R_{eq2}} + \frac{v_t}{R_{eq2}} \quad (125)$$

The flow graph for these equations is shown in Fig. 18. The determinant is given by

$$\Delta = 1 - \left[R_{eq1} \left(\frac{-A_0}{R_{eq2}} \right) b \right] = 1 + b R_{eq1} \frac{A_0}{R_{eq2}} = 1 + bA \quad (126)$$

From the flow graph, the current gain is given by

$$\frac{i_o}{i_s} = \frac{1}{\Delta} R_{eq1} \left(\frac{-A_0}{R_{eq2}} \right) = \frac{-R_{eq1} A_0 / R_{eq2}}{1 + b R_{eq1} A_0 / R_{eq2}} = \frac{-A}{1 + bA} \quad (127)$$

It follows that A is given by

$$A = R_{eq1} \frac{A_0}{R_{eq2}} \quad (128)$$

This is the negative of the gain from i_s to i_o with $b = 0$. If $bA \gg 1$, the gain approaches

$$\frac{i_o}{i_s} \rightarrow \frac{-A}{bA} = -\frac{1}{b} = -\left(1 + \frac{R_F}{R_1} \right) \quad (129)$$

This is the gain obtained by assuming the op amp is ideal. In this case, there is a virtual ground at its inverting input which causes $i_e = i_s + bi_o = 0$. Solution for i_o yields $i_o = -i_s/b$.

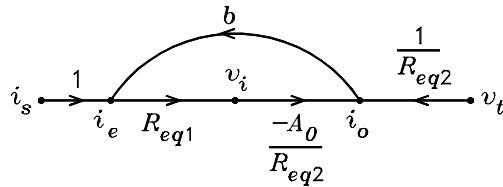

Figure 18: Flow graph for the shunt-series amplifier.

The input resistance r'_{in} and the output resistance r_{out} are given by

$$r'_{in} = \frac{v_i}{i_s} = \frac{1}{\Delta} R_{eq1} = \frac{R_S \parallel (R_1 + R_F) \parallel R_{id}}{1 + bA} \quad (130)$$

$$r_{out} = \left(\frac{i_o}{v_t} \right)^{-1} = \left(\frac{1}{\Delta} \frac{1}{R_{eq2}} \right)^{-1} = (1 + bA) (R_0 + R_L + R_1 \parallel R_F) \quad (131)$$

Note that the effect of the feedback is to reduce the gain, decrease the input resistance and increase the output resistance. In the case $bA \rightarrow \infty$, the output resistance becomes infinite and the load resistor R_L is driven by an ideal current source. The gain from v_s to i_o in the original circuit, the input resistance r_{in} , and the output resistance r'_{out} seen by R_L are given by

$$\frac{i_o}{v_s} = \frac{i_s}{v_s} \frac{i_o}{i_s} = \frac{1}{R_S} \frac{-A}{1+bA} = \frac{1}{R_S} \frac{-A}{1+bA} \quad (132)$$

$$r_{in} = R_S + \left(\frac{1}{r'_{in}} - \frac{1}{R_S} \right)^{-1} \quad (133)$$

$$r'_{out} = r_{out} - R_L \quad (134)$$